

F01 操纵总成 CONTROL ASSY.

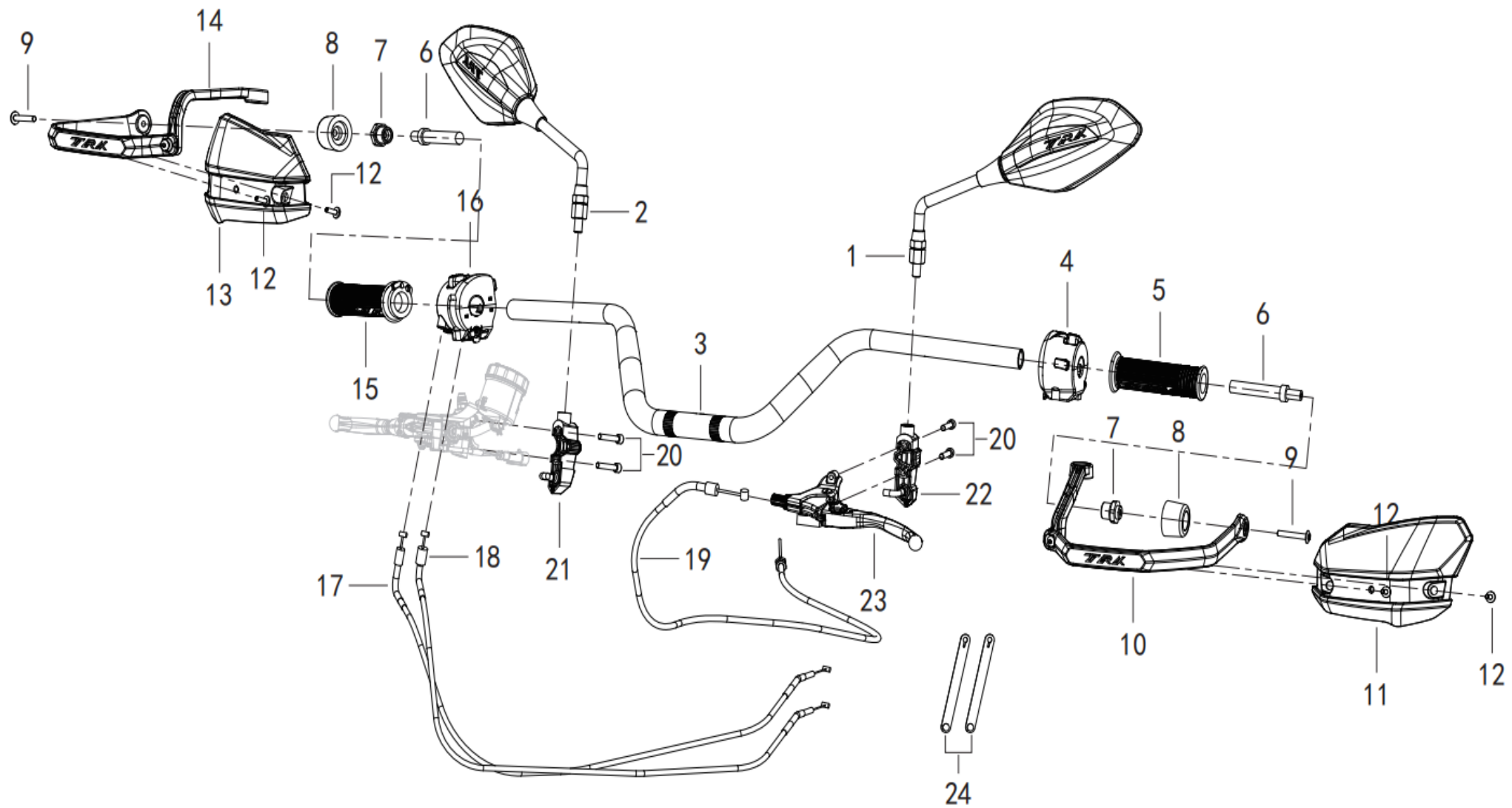

POSITION NO.	CODE	CN DESCRIPTION	EN DESCRIPTION	QTY / UNIT	REMARKS
F01-01	40450P160000	左后视镜组件	MIRROR ASSY.,RR VIEW,L.	1	
F01-02	40480P160000	右后视镜组件	MIRROR ASSY.,RR VIEW,R.	1	
F01-03	40101P380000	方向把	HANDLE BAR ASSY	1	
F01-04	40500N490001	左组合开关	SWITCH ASSY., L.	1	10 pin
F01-04	40500N490003	左组合开关	SWITCH ASSY., L.	1	9 pin
F01-04	40500P370002	左组合开关	SWITCH ASSY., L.	1	Brembo version
F01-05	40001P160100	左方向把套	GRIP ASSY.,L.	1	
F01-06	40031S010000	平衡块	BALANCER	2	
F01-07	40032P250000	平衡块安装座	BALANCE PIECE INSTALLED A	2	
F01-08	40031P160000	平衡块	BALANCER	2	
F01-09	08002P620006	内六角花形法兰面螺钉M6×40	HEXAGON SOCKET FLANGE SCREW M6×40	2	
F01-10	65210P16002Z	左把手护罩铝支架组合件	SHIELD ALUMINUM BRACKET	1	
F01-11	65216P160001	左把手护罩	HANDLE GUARD., L.	1	
F01-12	08001P620101	内六角花形法兰面螺钉M5×16	HEXAGON SOCKET FLANGE SCREW M5×16	4	
F01-13	65217P160001	右把手护罩	HANDLE GUARD., R.	1	
F01-14	65220P16003Z	右把手护罩铝支架组合件	SUPPORT ROD ASSY,RIGHT PROTECT COVER	1	
F01-15	40210P160100	右握把组件	GRIP ASSY.,R.	1	
F01-16	40600N490002	右组合开关	SWITCH ASSY., R.	1	5 pin
F01-16	40600N490012	右组合开关	SWITCH ASSY., R.	1	
F01-16	40600P370004	右组合开关	SWITCH ASSY., R.	1	Brembo version
F01-17	40300P380001	油门线组件I	THROTTLE CABLE ASSEMBLY I	1	
F01-18	40330P380001	油门线组件II	THROTTLE CABLE ASSEMBLY II	1	
F01-19	40400P380002	离合器线组件	CLUTCH LINE ASSEMBLY	1	
F01-20	B0226060306S	内六角花形圆柱头螺钉M6×30	HEXAGON SOCKET HEAD CAP SCREW M6×30	4	
F01-21	70190P370001	仪表调节开关 (右)	INSTRUMENT ADJUSTMENT SWITCH	1	
F01-22	70190P370000	仪表调节开关 (左)	INSTRUMENT ADJUSTMENT SWITCH	1	
F01-23	40080P410100	左手柄组件	HANDGRIP ASSY,L	1	
F01-24	40023P250000	方向把软线夹	CLIP,RUBBER	2	

F02 前叉总成 FORK ASSY.

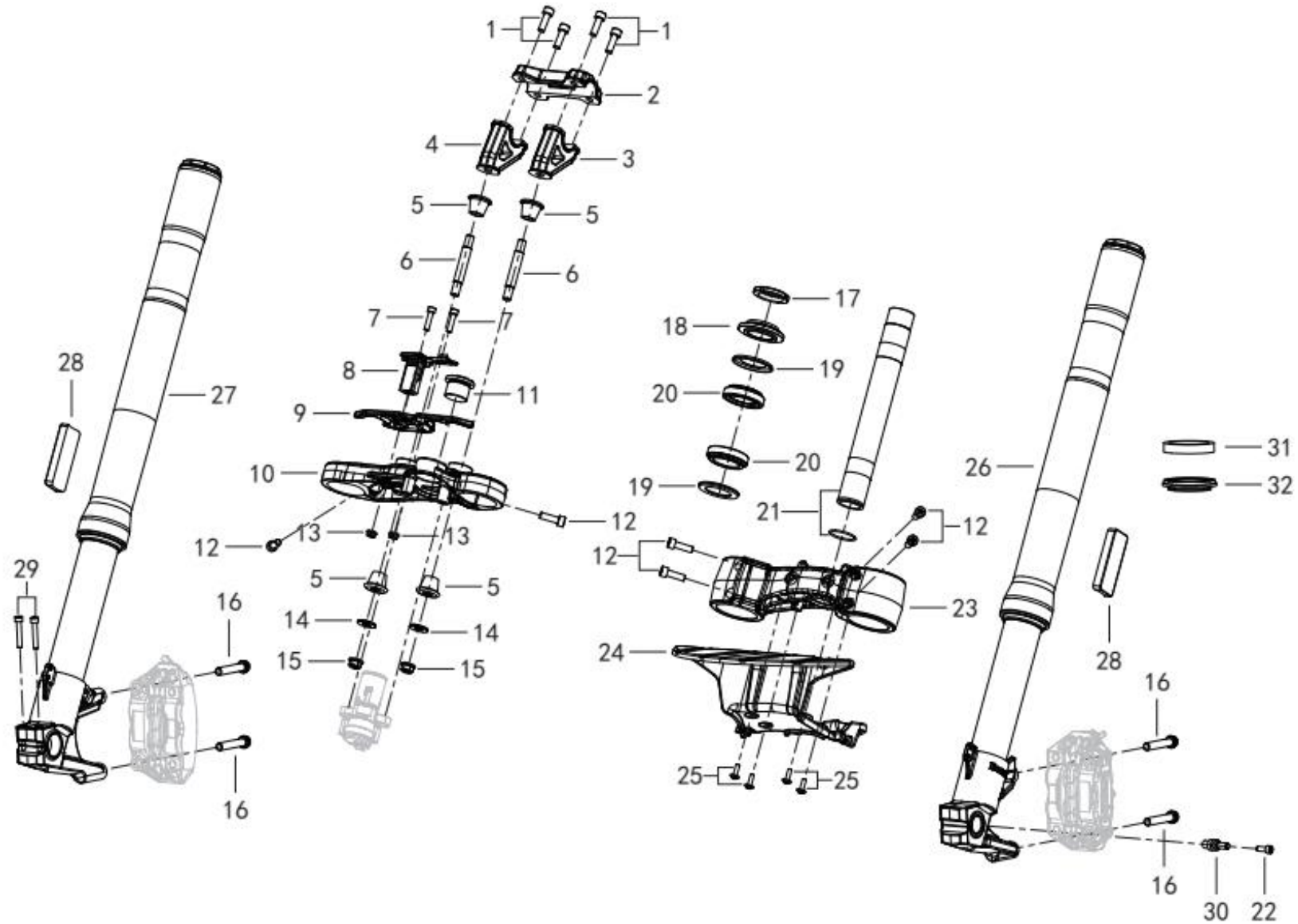

POSITION NO.	CODE	CN DESCRIPTION	EN DESCRIPTION	QTY / UNIT	REMARKS
F02-01	B0226080256K	内六角花形圆柱头螺钉M8×25	HEXAGON SOCKET HEAD CAP SCREW M8×25	4	
F02-02	43014P380000	方向把上座	SEAT ON THE STEERING HANDLE	1	
F02-03	43013P260005	左方向把下座	LOWER LEFT HANDLEBAR	1	
F02-04	43065P260005	右方向把下座	LOWER THE RIGHT-HAND SEAT	1	

POSITION NO.	CODE	CN DESCRIPTION	EN DESCRIPTION	QTY / UNIT	REMARKS
F02-05	47015P010010	消音塞	SILENCING PLUG	4	
F02-06	40086P260002	把手定位双头螺柱	HANDLE POSITIONING STUD	2	
F02-07	B0226060256S	内六角花形圆柱头螺钉M6×25	HEXAGON SOCKET HEAD CAP SCREW M6×25	2	
F02-08	99700S070000	车载USB充电器	VEHICLE USB CHARGER	1	
F02-09	57312P380000	USB安装板	USB MOUNTING BOARD	1	
F02-10	43011P370001	上联板	UPPER CONNECTING PLATE	1	
F02-11	43049P250000	上联板紧固螺钉	UPPER CONNECTING PLATE FASTENING SCREW	1	
F02-12	B0226080256S	内六角花形圆柱头螺钉M8×25	HEXAGON SOCKET HEAD CAP SCREW M8×25	6	
F02-13	B0407060005H	螺母M6	NUT M6	2	
F02-14	40089P010100	把手定位垫片	HANDLE POSITIONING GASKET	2	
F02-15	B04821012552	自锁螺母M10×1.25	SELF LOCKING NUT×1.25	2	
F02-16	08006P620001	六角螺钉M10×1.25×55	THIN HEXAGON FLANGE SCREW M10×1.25×55	4	
F02-17	43008S010010	上联板紧固螺母	FASTENING NUT OF UPPER CONNECTING PLATE	1	
F02-18	43009P260000	螺母	NUT	1	
F02-19	43005S010000	防尘圈	DUST RING	2	
F02-20	43130S010000	转向轴承	STEERING BEARING	2	
F02-21	43101P25000Z	方向柱防松环组合	COLUMN	1	
F02-22	B0226060166S	内六角花形圆柱头螺钉M6×16	HEXAGON SOCKET HEAD CAP SCREW M6×16	1	
F02-23	43102P370001	下联板	LOWER CONNECTING PLATE	1	
F02-24	65102P380000	前内挡泥板	FRONT INNER FENDER	1	
F02-25	08001P620101	内六角花形法兰面螺钉M5×16	HEXAGON SOCKET FLANGE SCREW M5×16	4	
F02-26	43200P38000A	前左减震器组件	FRONT LEFT SHOCK ABSORBER ASSEMBLY	1	
F02-26	43200P380007	前左减震器组件	FRONT LEFT SHOCK ABSORBER ASSEMBLY	1	Brembo version
F02-27	43300P38000A	前右减震器组件	FRONT RIGHT SHOCK ABSORBER ASSEMBLY	1	
F02-27	43300P380007	前右减震器组件	FRONT RIGHT SHOCK ABSORBER ASSEMBLY	1	Brembo version
F02-28	86200P250001	前侧反射体	FRONT REFLECTOR	2	
F02-29	B0226060356S	内六角花形圆柱头螺钉M6×35	HEXAGON SOCKET HEAD CAP SCREW M6×35	2	
F02-30	45710P370001	前后轮轮速传感器II	FRONT AND REAR WHEEL SPEED SENSOR II	1	
F02-31	43260P380001	油封组件	OIL SEAL	2	
F02-31	43260P160006	油封组件	OIL SEAL	2	Brembo version
F02-32	43290P380001	防尘圈组件	DUST RING ASSEMBLY	2	
F02-32	43290P160006	防尘圈组件	DUST RING ASSEMBLY	2	Brembo version

F03A 前轮总成 FRONT WHEEL ASSY.

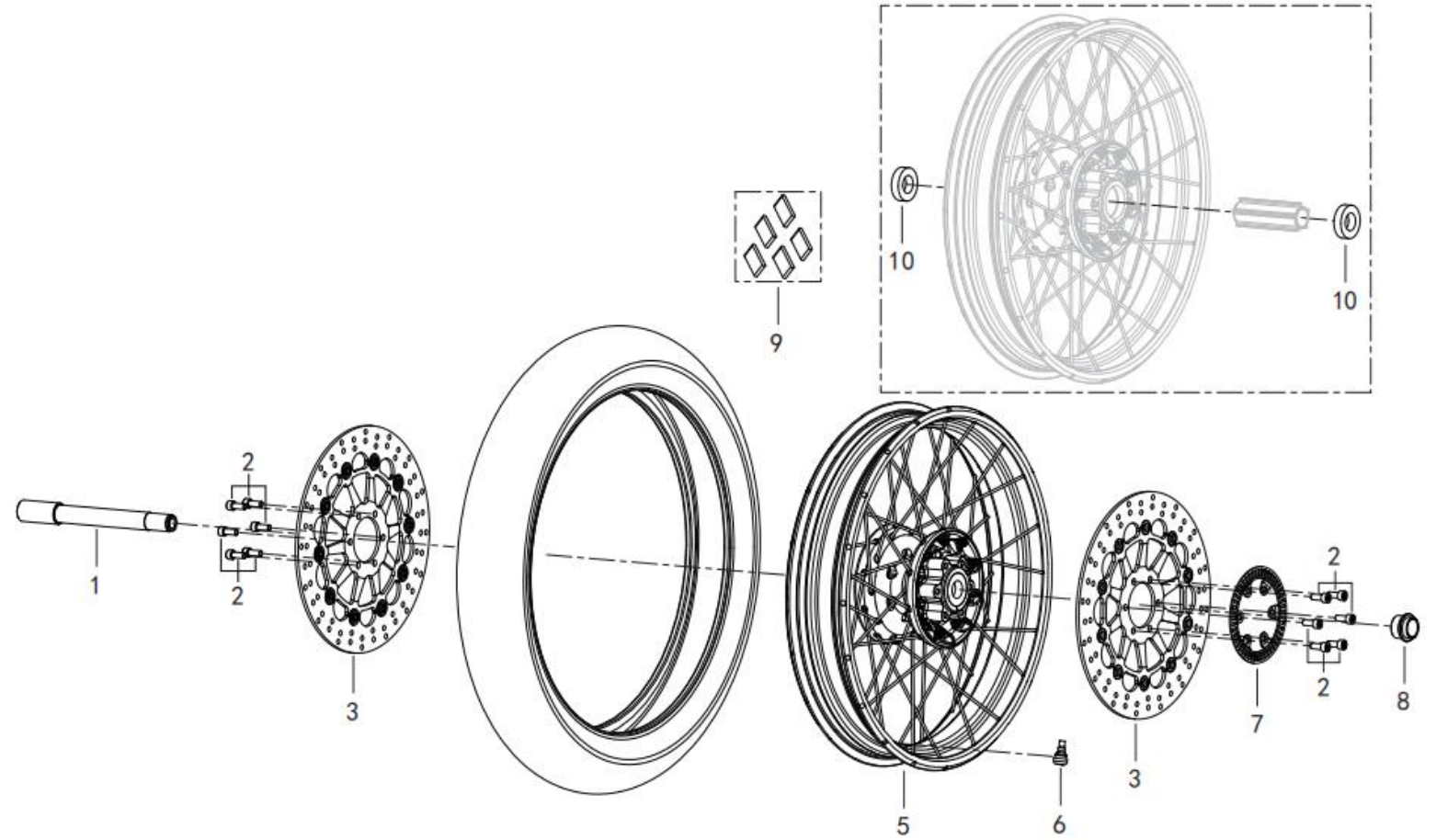
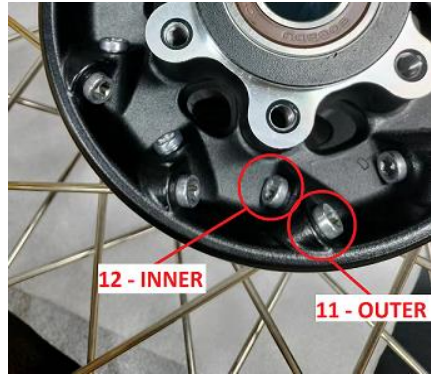

POSITION NO.	CODE	CN DESCRIPTION	EN DESCRIPTION	QTY / UNIT	REMARKS
F03A-01	44004S010010	前轮轴	FRONT WHEEL SHAFT	1	
F03A-02	B0226080206S	内六角花形圆柱头螺钉M8×20	HEXAGON SOCKET HEAD CAP SCREW M8×20	12	
F03A-03	45030P250003	前制动盘组件	FRONT BRAKE DISC	2	
F03A-05	44100P16003Z	前轮圈组件/辐条款	FRONT WHEEL ASSY	1	
F03A-06	B1403Z201100	气门嘴	RIM VALVE	1	
F03A-07	45702P250000	ABS前轮齿圈	ABS FRONT GEAR RING	1	
F03A-08	44005S010000	前轮左隔套	SLEEVE GASKET	1	
F03A-09	44091P290000	5克动平衡块	BALANCE WEIGHT 5g	5	
F03A-10	B12016000507	滚动轴承6005-2RS/C3	ROLLING BEARING 6005-2RS/C3	2	
F03A-11	44011P160001	前轮外侧辐条	FRONT WHEEL OUTER SPOKE	20	
F03A-12	44012P160001	前轮内侧辐条	FRONT WHEEL INNER SPOKE	20	



F04 液刹总成 FRONT DISK BRAKE ASSY.

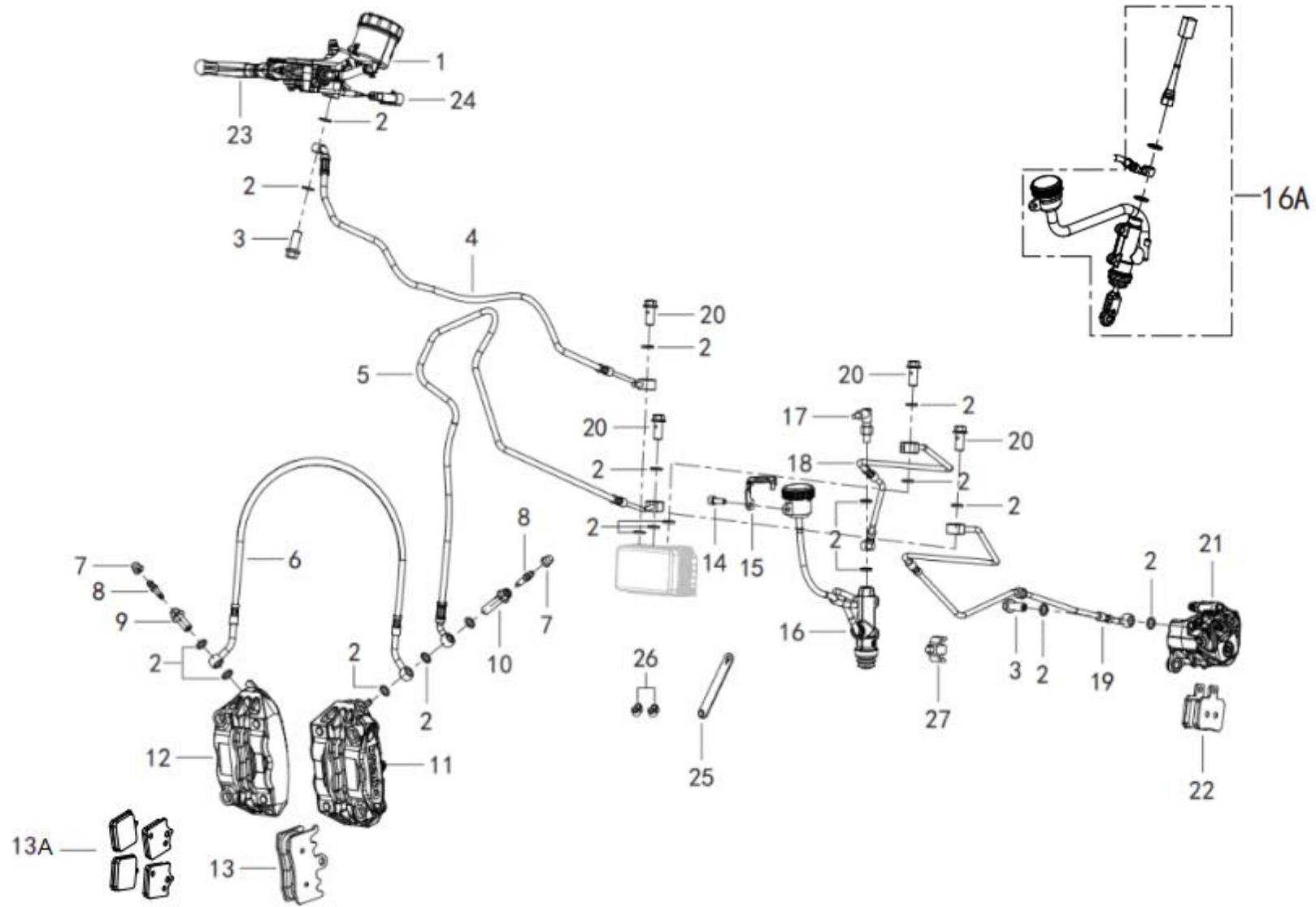

POSITION NO.	CODE	CN DESCRIPTION	EN DESCRIPTION	QTY / UNIT	REMARKS
F04-01	45400P410000	前油泵体组件	MASTER CYLINDER,FRONT DISK BRAKE	1	
F04-01	45400P380200	前油泵体组件	MASTER CYLINDER,FRONT DISK BRAKE	1	Brembo version
F04-02	45078P300000	垫圈	WASHER	19	
F04-03	55037P300100	油管安装螺栓	OIL DRAIN BOLT	2	

POSITION NO.	CODE	CN DESCRIPTION	EN DESCRIPTION	QTY / UNIT	REMARKS
F04-04	45240P380001	前液刹油管总成I	FRONT DISC BRAKE HOSE ASSY.I	1	
F04-05	45270P380001	前液刹油管总成II	FRONT DISC BRAKE HOSE ASSY.II	1	
F04-05	45270P380000	前液刹油管总成II	FRONT DISC BRAKE HOSE ASSY.II	1	Brembo version
F04-06	45250P380000	前液刹油管总成III	FRONT DISC BRAKE HOSE ASSY.	1	
F04-07	45021B510000	放气嘴防尘罩	COVER,ANTI-DUST, DEFLATING VALVE	2	
F04-08	45019N100100	放气嘴	DEFLATING VALVE	2	
F04-09	45037P360100	油管安装螺栓	OIL DRAIN BOLT	1	
F04-10	45037P150101	油管安装螺栓	OIL DRAIN BOLT	1	
F04-11	45500S010110	前左制动缸组件/TNT1130	HYDROCHECK ASSY.LEFT,SILVER WHITE	1	
F04-11	45500P280000	前左制动缸组件/Brembo	HYDROCHECK ASSY.LEFT,SILVER WHITE	1	Brembo version
F04-12	45600S010110	前右制动缸组件/TNT1130	HYDROCHECK ASSY.RIGHT,SILVER WHITE	1	
F04-12	45600P280000	前右制动缸组件/Brembo	HYDROCHECK ASSY.RIGHT,SILVER WHITE	1	Brembo version
F04-13A	45120S010030	前液刹片(8只)	FRONT BRAKE PAD ASSY.	1set	
F04-13	45120P280000	前液刹片/Brembo	FRONT BRAKE PAD ASSY.	2set	Brembo version
F04-14	B0226060166S	内六角花形圆柱头螺钉M6×16	HEXAGON SOCKET HEAD CAP SCREW M6×16	1	
F04-15	57041V030001	油杯防拆盖	OIL CUP COVER	1	
F04-16A	55400P090002	后油泵体组件	MASTER CYLINDER,REAR DISC BRAKE	1	
F04-16	55400P380000	后油泵体组件/brembo	MASTER CYLINDER,REAR DISC BRAKE	1	Brembo version
F04-18	55270P380000	后液刹油管总成II	REAR DISC BRAKE HOSE ASSY.II	1	
F04-19	55240P380000	后液刹油管总成I	REAR DISC BRAKE HOSE ASSY.I	1	
F04-20	55037P250100	ABS油管螺栓	BOLT	4	
F04-21	55500P250101	后制动缸组件	HYDROCHECK ASSY,REAR DISC BRAKE	1	
F04-21	55500P360400	后制动缸组件/brembo	HYDROCHECK ASSY,REAR DISC BRAKE	1	Brembo version
F04-22	55120P300001	后液刹片	REAR BRAKE PADS ASSY	1set	
F04-22	55120P360000	后液刹片/Brembo	REAR BRAKE PADS ASSY	1set	Brembo version
F04-23	45020P410000	前手柄组件	CLUTCH LEVER	1	
F04-23	45020P380000	前手柄组件/Brembo	CLUTCH LEVER	1	Brembo version
F04-24	45300P410000	前制动开关组件	FRONT BRAKE SWITCH ASSEMBLY	1	
F04-24	45300P380000	前制动开关组件/Brembo	FRONT BRAKE SWITCH ASSEMBLY	1	Brembo version
F04-25	49371T620001	截止阀软线夹	STOP VALVE CLAMP	2	
F04-26	50920S070000	传感器线卡扣	SENSOR LINE CLIP	2	
F04-27	65842P290000	两道带支座管卡	TWO PIPE CLAMPS WITH SUPPORTS	1	

F05 消声器总成 MUFFLER ASSY.

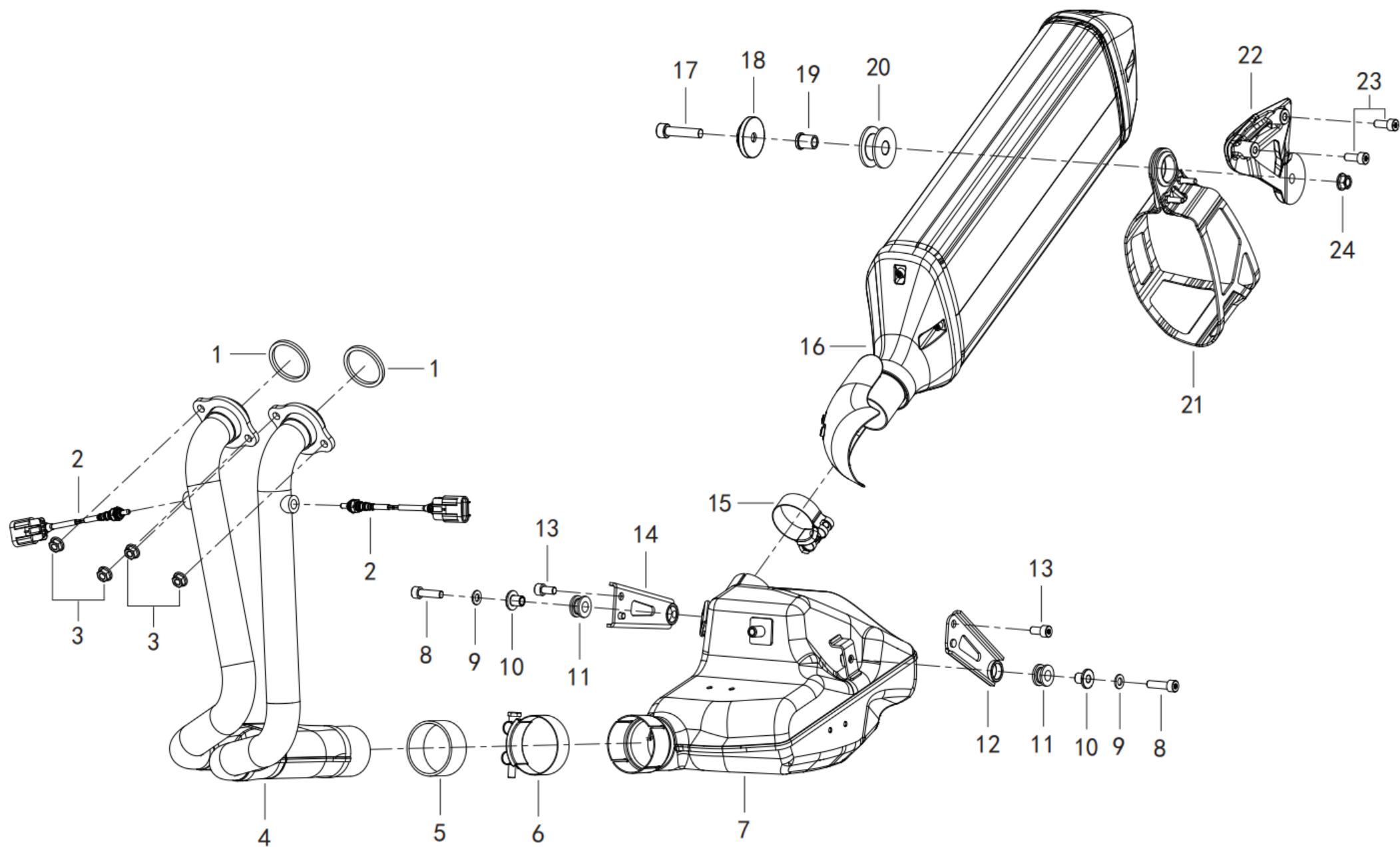



POSITION NO.	CODE	CN DESCRIPTION	EN DESCRIPTION	QTY / UNIT	REMARKS
F05-01	47800S010000	排气口衬垫	EXHAUST PORT GASKET	2	
F05-02	280586030000	氧传感器	OXYGEN SENSOR	2	
F05-03	B0407080005H	螺母M8	NUT M8	4	
F05-04	47500P370020	排气管组件	EXHAUST PIPE ASSEMBLY	1	
F05-05	47036P290000	石墨衬圈	GRAPHITE LINER	1	
F05-06	47830P300000	卡箍Φ65	CLAMP Φ 65	1	
F05-07	47200P380020	筒体组件 I	CYLINDER ASSEMBLY I	1	
F05-08	B0226080306S	内六角花形圆柱头螺钉M8×30	HEXAGON SOCKET HEAD CAP SCREW M8×30	2	
F05-09	B0703000080H	垫圈8	WASHER 8	2	
F05-10	65613P260000	护板衬套	SHIELD BUSHING	2	
F05-11	65617H010000	橡胶套II	RUBBER SLEEVE II	2	
F05-12	47610P370000	消音器左安装板组件	MUFFLER LEFT MOUNTING PLATE ASSEMBLY	1	
F05-13	B0226080166S	内六角花形圆柱头螺钉M8×16	HEXAGON SOCKET HEAD CAP SCREW M8×16	2	
F05-14	47620P370000	消音器右安装板组件	MUFFLER RIGHT MOUNTING PLATE ASSEMBLY	1	
F05-15	47830P160000	卡箍组件	CLAMP AS	1	
F05-16	48200P380020	筒体组件II	CYLINDER ASSEMBLY II	1	
F05-17	B0276100456P	内六角圆柱螺钉M10×1.25×45	HEXAGON SOCKET HEAD CAP SCREW M10×1.25×45	1	
F05-18	47029P160000	装饰盖	DECORATIVE COVER	1	
F05-19	47028P160000	筒体缓冲衬套	CYLINDER BUFFER SLEEVE	1	
F05-20	47027P160000	消声器橡胶套	MUFFLER RUBBER SLEEVE	1	
F05-21	47830P160002	抱箍组件	HOOP ASSEMBLY	1	
F05-22	47601P380000	消声器安装支架	MUFFLER MOUNTING BRACKET	1	
F05-23	B0226080206S	内六角花形圆柱头螺钉M8×20	HEXAGON SOCKET HEAD CAP SCREW M8×20	2	
F05-24	B04821012552	自锁螺母M10×1.25	SELF LOCKING NUT M10×1.25	1	

F06 空滤器总成 AIR CLEANER ASSY.

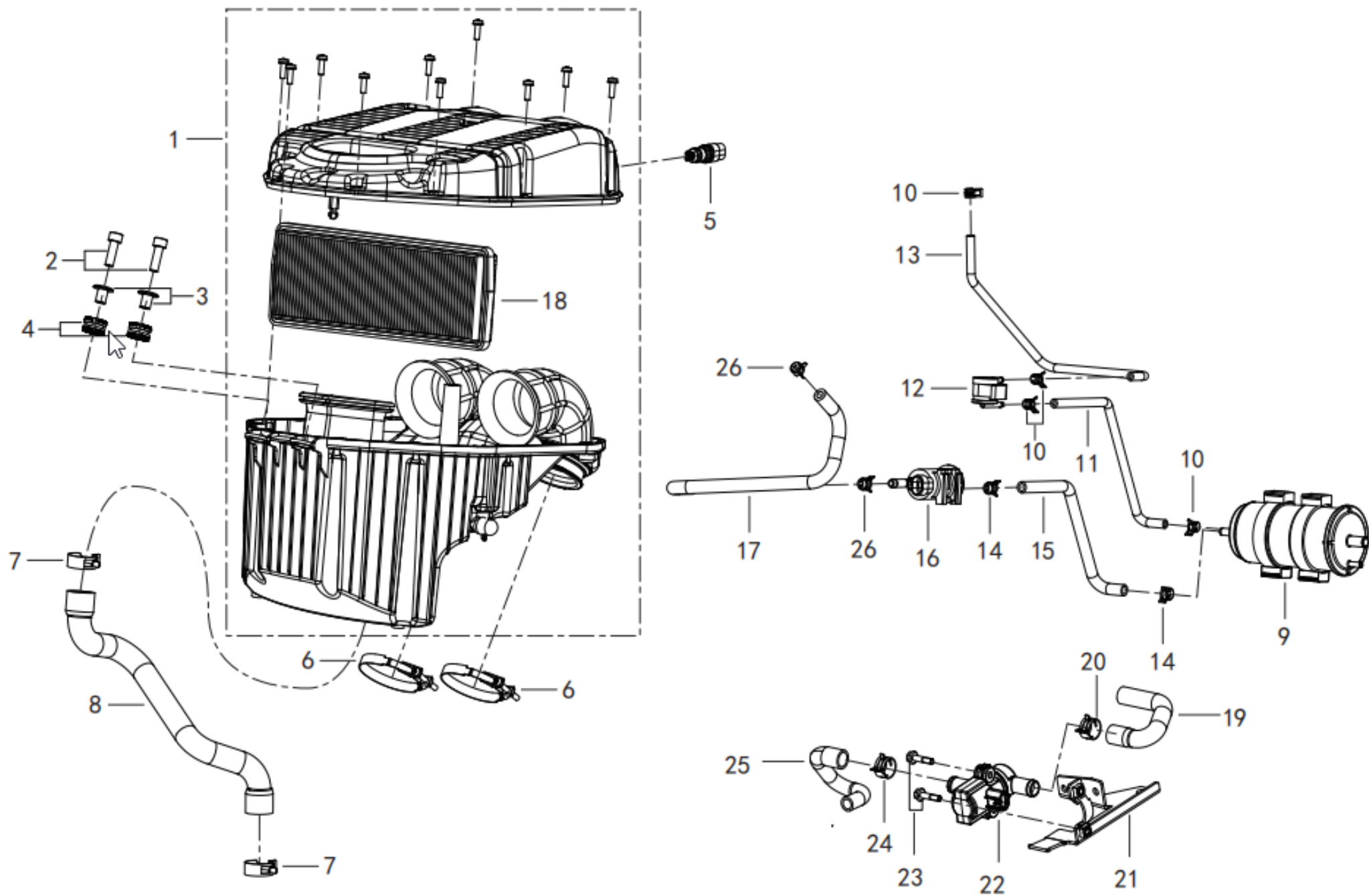

POSITION NO.	CODE	CN DESCRIPTION	EN DESCRIPTION	QTY / UNIT	REMARKS
F06-01	49100P370001	空滤器组件	EMPTY FILTER COMPONENTS	1	
F06-02	B0226080256S	内六角花形圆柱头螺钉M8×25	HEXAGON SOCKET HEAD CAP SCREW M8×25	2	
F06-03	14003S040200	散热器上衬套	THE RADIATOR ON THE BUSHING	2	
F06-04	65821S010000	橡胶块	RUBBER BLOCK	2	
F06-05	310015040000	进气温度传感器	TEMPERATURE SENSOR	2	
F06-06	280426030000	卡箍组件	CLIP ASSY	2	
F06-07	49805J000200	耐热管卡箍	HEAT RESISTANT PIPE CLAMP	2	
F06-08	49025P370000	废气回收管	WASTE GAS RECOVERY TUBE	1	
F06-09	49912K670020	碳罐组合	CARBON TANK	1	
F06-10	49016B350300	板式卡箍	PLATE CARD HOOP	4	
F06-11	49921P370000	单向阀与碳罐连接管	ONE-WAY VALVE WITH CARBON CANISTER TUBE	1	
F06-12	49930G410000	单向阀组件	CHECK VALVE COMPONENTS	1	
F06-13	49924P370000	油箱与单向阀连接管	TANK AND CHECK VALVE CONNECTING PIPE	1	
F06-14	50307J140302	板式卡箍	PLATE CARD HOOP	2	
F06-15	49922P370000	碳罐与电磁阀连接管	CANISTER AND ELECTROMAGNETIC VALVE CONNECTING PIPE	1	
F06-16	49710N070000	碳罐电磁阀	CANISTER SOLENOID VALVE	1	
F06-17	49923P370000	电磁阀与节流阀体连接管	SOLENOID VALVE AND THROTTLE VALVE CONNECTING PIPE	1	
F06-18	49200P370000	滤芯组件	FILTER COMPONENTS	1	
F06-19	49809P380000	补气阀与空滤器连接管	CONNECTING PIPE BETWEEN AIR MAKEUP VALVE AND AIR FILTER	1	
F06-20	50306J690000	卡箍13.3-706R	CLAMP 13.3-706R	1	
F06-21	59610P380000	补气阀安装座	AIR SUPPLY VALVE MOUNTING SEAT	1	
F06-22	49760P090000	电控补气阀	ELECTRICALLY CONTROLLED AIR SUPPLY VALVE	1	
F06-23	08001P620100	内六角花形法兰面螺钉M5×12	BOLT M5×12	2	
F06-24	50307J690000	卡箍14.5-706R	CLAMP 14.5-706R	1	
F06-25	49808P380000	补气阀与缸头连接管	CONNECTING PIPE BETWEEN AIR MAKEUP VALVE AND CYLINDER HEAD	1	
F06-26	49016P290000	板式卡箍	PLATE CLAMP	2	



POSITION NO.	CODE	CN DESCRIPTION	EN DESCRIPTION	QTY / UNIT	REMARKS
F07-01	B0226050146A	内六角花形圆柱头螺钉M5×14	HEXAGON SOCKET HEAD CAP SCREW M5×14	3	
F07-02	B0226050306A	内六角花形圆柱头螺钉M5×30	HEXAGON SOCKET HEAD CAP SCREW M5×30	3	
F07-03	65618J000000	护板橡胶垫丙	RUBBER PAD OF GUARD PLATE	2	
F07-04	160306030080	六角内梅花螺栓M6×35	HEXAGON INNER RING BOLT M6×35	2	
F07-05	08023J000100	油箱安装垫圈	OIL TANK MOUNTING WASHER	2	
F07-06	50221J000101	油箱安装轴套	OIL TANK MOUNTING SLEEVE	2	
F07-07	50222J000001	橡胶套	RUBBER SLEEVE	2	
F07-08	65618P410000	油箱护板橡胶	OIL TANK GUARD RUBBER	2	
F07-09	50100P380000	油箱体组件	FUEL TANK BODY ASSEMBLY	1	
F07-10	50006J000001	油箱垫板	FUEL TANK BASE PLATE	1	
F07-11	B0226080206S	内六角花形圆柱头螺钉M8×20	HEXAGON SOCKET HEAD CAP SCREW M8×20	1	
F07-12	B0703000080H	垫圈8	WASHER 8	1	
F07-13	50027P370000	油箱前安装板	OIL TANK FRONT MOUNTING PLATE	1	
F07-14	50005P250000	油箱前安装垫	OIL TANK FRONT MOUNTING PAD	3	
F07-15	08021H070100	垫圈	WASHER	3	
F07-16	B0407060005H	螺母M6	NUT M6	3	
F07-17	08012P620002	内六角凹穴螺栓M5×20	HEXAGON SOCKET HEXAGON FLANGE BOLT M5×20	14	
F07-18	50800P380001	低油位传感器	LOW OIL LEVEL SENSOR	1	
F07-19	50808P250010	油位传感器密封圈	SEALING RING OF OIL LEVEL SENSOR	2	
F07-20	50800P380000	油位传感器组件	SENSOR AS-OIL LEVEL	1	
F07-21	50400P290000	燃油泵	FUEL PUMP	1	
F07-22	50080P380000	油管组件I	TUBING ASSEMBLY I	1	
F07-23	50340N070000	过滤器组件	FILTER ASSEMBLY	1	
F07-24	50391N070010	过滤器护套	FILTER SHEATH	1	
F07-25	50070P380000	油管组件II	TUBING ASSEMBLY II	1	



F08 后摆臂总成 REAR SWINGING ARM ASSY.

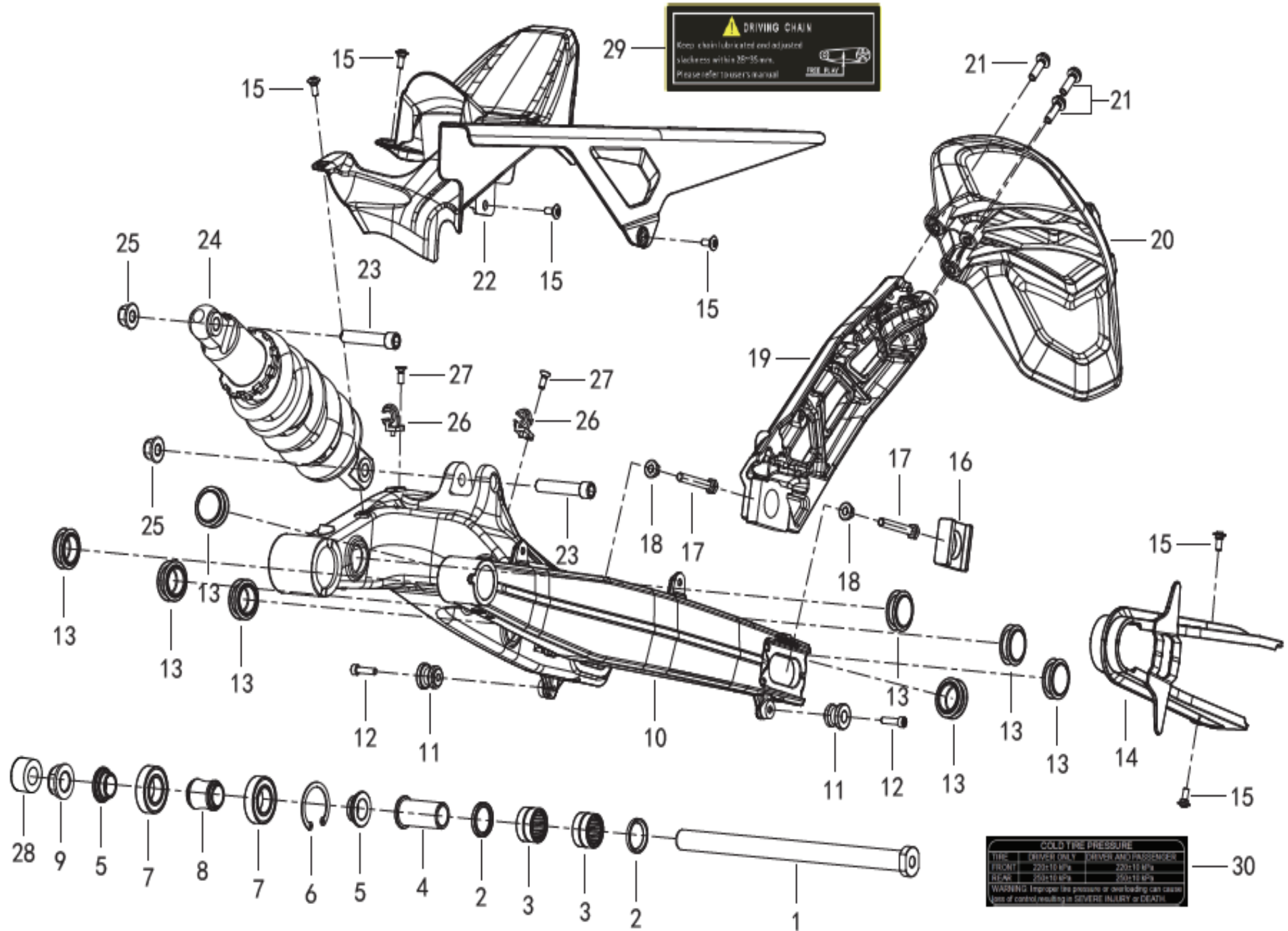

POSITION NO.	CODE	CN DESCRIPTION	EN DESCRIPTION	QTY / UNIT	REMARKS
F08-01	53001P370001	后摆臂轴	REAR SWING ARM SHAFT	1	
F08-02	53220P370000	后摆臂油封组件	OIL SEAL ASSEMBLY OF REAR SWING ARM	2	
F08-03	B1210H262001	滚针轴承NK26/20	NEEDLE ROLLER BEARING NK26/20	2	
F08-04	53005P380000	左摆臂中间衬套	MIDDLE BUSH OF LEFT SWING ARM	1	
F08-05	53006P370000	摆臂外衬套	OUTER BUSHING OF SWING ARM	2	
F08-06	B08000004701	孔用弹性挡圈φ47	ELASTIC RING FOR HOLE Φ FORTY-SEVEN	1	
F08-07	B12016000500	滚动轴承6005-2RS	ROLLING BEARING 6005-2RS	1	
F08-08	53007P370000	右摆臂中间衬套	MIDDLE BUSH OF RIGHT SWING ARM	1	
F08-09	08051P100100	自锁螺母M20×1.5	SELF LOCKING NUT M20×1.5	1	
F08-10	53101P380000	后摆臂	REAR SWING ARM	1	
F08-11	53021P250000	支撑套	SUPPORT SLEEVE	2	
F08-12	B0226060256S	内六角花形圆柱头螺钉M6×25	HEXAGON SOCKET HEAD CAP SCREW M6×25	2	
F08-13	53017P380000	后摆臂堵头	REAR SWING ARM PLUG	8	
F08-14	53004P380000	链条缓冲块	CHAIN BUFFER BLOCK	1	
F08-15	08003P620100	内六角法兰面台阶螺钉M6×15	HEXAGON SOCKET FLANGE STEP SCREW M6×15	6	
F08-16	60152P290000	右链条调节块	RIGHT CHAIN ADJUSTING BLOCK	1	
F08-17	08002P300010	链条调节螺钉M8	CHAIN ADJUSTING SCREW M8	2	
F08-18	B0407080005H	螺母M8	NUT M8	2	
F08-19	65772P290004	后下挡泥板支架II	REAR LOWER FENDER BRACKET II	1	
F08-20	65761P160002	后下挡泥板	REAR LOWER FENDER	1	
F08-21	08005P620003	六角花形法兰面螺钉M8×25	THIN HEXAGON FLANGE SCREW M8×25	3	
F08-22	60101P380001	链罩	CHAIN COVER	1	
F08-23	08013P290000	后减震器上固定螺栓	REAR SHOCK ABSORBER UPPER FIXING BOLT	2	
F08-24	63800P380004	后减震器组件	SHOCK ABSORBER AS-REAR	1	
F08-24	63800P380005	后减震器组件	SHOCK ABSORBER AS-REAR	1	Brembo version
F08-25	B04821212552	螺母M12×1.25	NUT M12×1.25	2	
F08-26	40022N050002	线夹	CLAMP	2	
F08-27	B0213060166S	内六角花形沉头螺钉M6×16	HEXAGON SOCKET COUNTERSUNK SCREW M6×16	2	
F08-28	53018P160000	支点轴护套	FULCRUM SHAFT SHEATH	1	

F09A-1 后轮总成 REAR WHEEL ASSY.

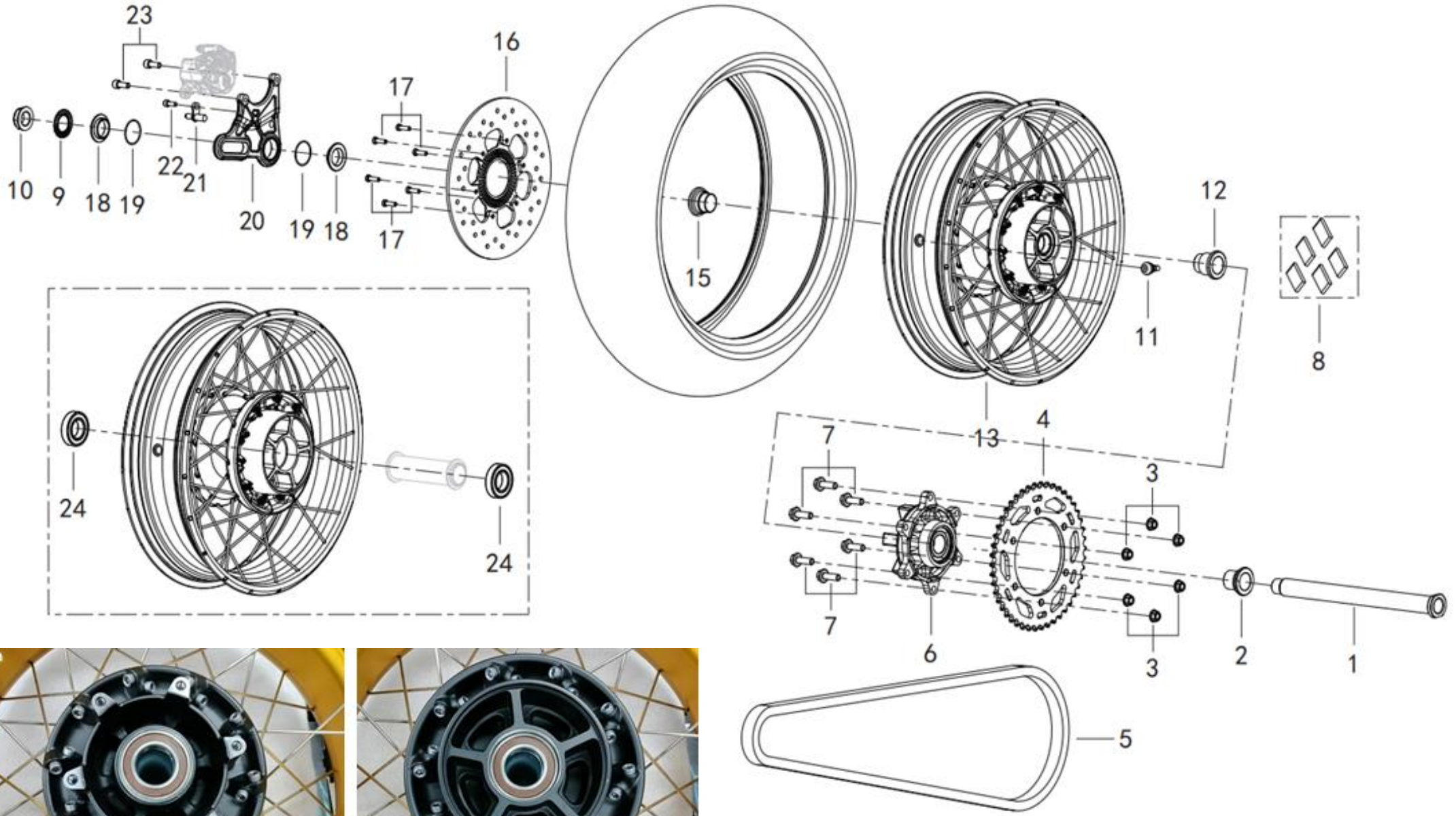

POSITION NO.	CODE	CN DESCRIPTION	EN DESCRIPTION	QTY / UNIT	REMARKS
F09A-01	54004P290000	后轮轴	REAR AXLE	1	
F09A-02	54016S010000	链轮轴套	DRIVE SHAFT SLEEVE,CHAIN	1	
F09A-03	B04821012552	自锁螺母M10×1.25	NUT M10×1.25	6	
F09A-04	60002P780000	链轮	SPROCKET	1	
F09A-05	65310P520000	链条525SX-1×118	CHAIN 525SX-1×118	1	
F09A-06	60001P38000Z	链轮毂组件	DRUM,SPROCKET MOUNTING	1	
F09A-07	08015P620003	内六角凹穴螺栓M10×1.25×30	BOLT, SPROCKET MOUNTING M10×1.25×30	6	
F09A-08	44091P290000	5克动平衡块	BALANCE WEIGHT 5g	5	
F09A-09	08041P290000	双面齿防松垫片	DOUBLE SIDED TOOTH LOCKING GASKET	1	
F09A-10	54019P300010	自锁螺母M24×1.5	NTU M24×1.5	1	
F09A-11	B1403Z201100	气门嘴	RIM VALVE	1	
F09A-12	54016P250001	后轮左轴套	REAR AXLE LEFT SLEEVE	1	
F09A-13	54100P16003Z	后轮圈组件	RAER WHEEL ASSY	1	
F09A-15	54005P290001	后轮隔套	BUSH,LEFT, REAR WHEEL	1	
F09A-16	55030P160000	后制动盘组件Φ260	DISK BRAKE Φ260	1	
F09A-17	B0282060208H	螺钉M6×20	SCREW M6×20	6	
F09A-18	54005P290000	后轮右衬套	BUSH,LEFT, REAR WHEEL	2	
F09A-19	B190103650A0	O型圈36.5×1.8	TYPE O LAP 36.5×1.8	2	
F09A-20	55401P370000	制动钳支撑板	BRAKE CLAMP SUPPORT PLATE	1	
F09A-21	45710P370001	前后轮轮速传感器II	FRONT AND REAR WHEEL SPEED SENSOR II	1	
F09A-22	B0226060166S	内六角花形圆柱头螺钉M6×16	HEXAGON SOCKET HEAD CAP SCREW M6×16	1	
F09A-23	B0226080206S	内六角花形圆柱头螺钉M8×20	HEXAGON SOCKET HEAD CAP SCREW M8×20	2	
F09A-24	B12016000600	滚动轴承6006-2RS	ROLLING BEARING 6006-2RS	2	
F09A-25	54011P160001	后轮右外侧辐条	REAR WHEEL RIGHT OUTER SPOKE	10	
F09A-26	44012P160001	后轮左内侧辐条	REAR WHEEL LEFT INNER SPOKE	10	
F09A-27	54012P160001	后轮左外侧辐条	REAR WHEEL LEFT OUTER SPOKE	10	
F09A-28	54012P160001	后轮右内侧辐条	REAR WHEEL RIGHT INNER SPOKE	10	



F10 车架总成 FRAME BODY ASSY.

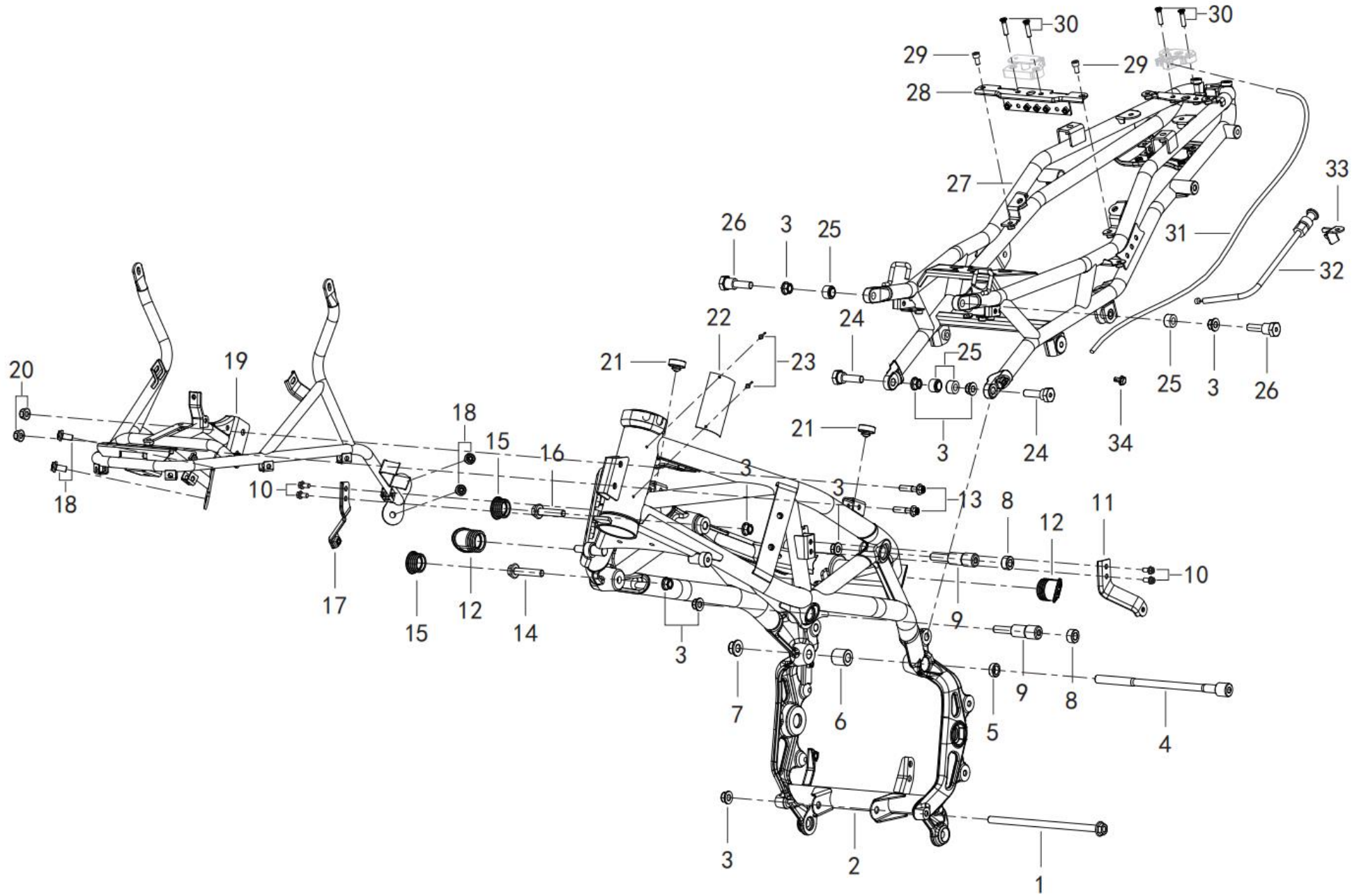

POSITION NO.	CODE	CN DESCRIPTION	EN DESCRIPTION	QTY / UNIT	REMARKS
F10-01	58303T430000	发动机固定轴	ENGINE FIXED SHAFT	1	



POSITION NO.	CODE	CN DESCRIPTION	EN DESCRIPTION	QTY / UNIT	REMARKS
F10-02	57110P380000	前车架焊接组件	WELDING COMPONENTS OF FRONT FRAME	1	
F10-03	B04821012552	自锁螺母M10×1.25	SELF LOCKING NUT M10×1.25	9	
F10-04	08011P370001	发动机后安装螺栓	ENGINE REAR MOUNTING BOLTS	1	
F10-05	57025P370000	发动机安装轴衬套	ENGINE MOUNTING SHAFT BUSHING	1	
F10-06	57018P370000	发动机安装衬套	ENGINE MOUNTING BUSH	1	
F10-07	B04821212552	螺母M12×1.25	NUT M12×1.25	1	
F10-08	40018S040010	发动机右前定位销	ENGINE RIGHT FRONT LOCATING PIN	2	
F10-09	08012P370000	发动机前安装螺栓	ENGINE FRONT MOUNTING BOLT	2	
F10-10	160306030010	六角内梅花螺栓	HEXAGON INNER RING BOLT M6×12	4	
F10-11	57610P380000	左前护板安装座	LEFT FRONT GUARD MOUNT	1	
F10-12	57015P380000	车架堵头	FRAME PLUG	2	
F10-13	160306030160	六角内梅花螺栓	HEXAGON INNER RING BOLT M8×35	2	
F10-14	08015P620006	内六角凹穴螺栓M10×1.25×50	HEXAGON FLANGE BOLT M10×1.25×50	1	
F10-15	57015P290000	车架堵头I	FRAME PLUG I	2	
F10-16	08015P620005	内六角凹穴螺栓M10×1.25×45	HEXAGON FLANGE BOLT M10×1.25×45	1	
F10-17	57620P380000	右前护板安装座	RIGHT FRONT GUARD MOUNT	1	
F10-18	08005P620000	六角花形法兰面螺钉M8×16	THIN HEXAGON FLANGE SCREW M8×16	4	
F10-19	59400P380000	前大罩支架组件	FRONT HOOD BRACKET ASSEMBLY	1	
F10-20	B0417080004H	自锁螺母M8	SELF LOCKING NUT M8	2	
F10-21	51103V030000	座垫缓冲橡胶圈	CUSHION CUSHION RUBBER RING	2	
F10-23	B100432007P0	抽芯铆钉3.2×7	BLIND RIVET 3.2×7	2	
F10-24	08012P380000	车架下固定螺栓	FIXING BOLTS UNDER THE FRAME	2	
F10-25	58306P160000	动力螺栓护套	POWER BOLT SHEATH	4	
F10-26	08011P380000	车架上固定螺栓	FIXING BOLTS ON THE FRAME	2	
F10-27	57120P380000	后车架焊接组件	WELDING COMPONENTS OF REAR FRAME	1	
F10-28	58950P380000	前座垫支撑座	FRONT SEAT CUSHION SUPPORT	1	
F10-29	B0226060126S	内六角花形圆柱头螺钉M6×12	HEXAGON SOCKET HEAD CAP SCREW M6×12	2	
F10-30	B0201060252S	十字槽沉头螺钉M6×25	CROSS COUNTERSUNK HEAD SCREW M6×25	4	
F10-31	58900P380000	座垫钢索组件	CUSHION CABLE ASSEMBLY	1	
F10-32	40680N300000	座垫钢索组件I	CUSHION CABLE ASSEMBLY I	1	
F10-33	58851P250200	座垫锁安装座	SEAT CUSHION LOCK MOUNT	1	
F10-34	08010P060000	搭铁螺栓组件	GROUND BOLT ASSEMBLY	6	

F11 中撑/单撑 MAIN STAND ASSY/SIDE STAND ASSY.

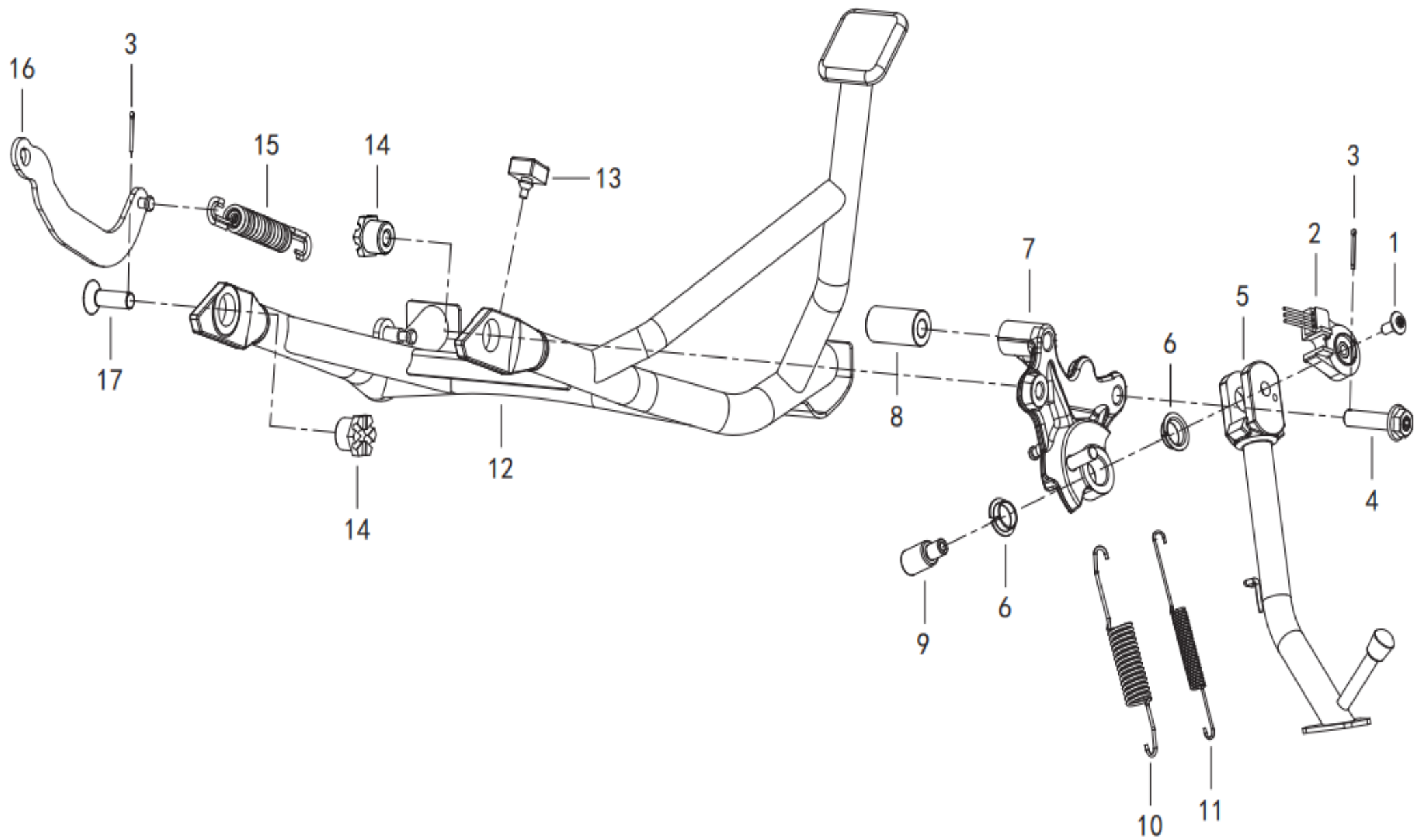

POSITION NO.	CODE	CN DESCRIPTION	EN DESCRIPTION	QTY / UNIT	REMARKS
F11-01	08002P620002	内六角花形法兰面螺钉M6×14	HEXAGON SOCKET FLANGE SCREW M6×14	1	
F11-02	91170TA70002	单撑熄火开关	SINGLE SUPPORT FLAMEOUT SWITCH	1	
F11-03	B090002025AH	开口销2×25	SPLIT PIN 2×25	2	
F11-04	08013P380000	内六角凹穴螺栓M10×1.25×42	HEXAGON FLANGE BOLT M10×1.25×42	1	
F11-05	58700P380001	单撑焊接组件	SINGLE SUPPORT WELDING ASSEMBLY	1	
F11-06	57031P380000	单撑减磨圈	SINGLE SUPPORT ANTIFRICTION RING	2	
F11-07	58030P380000	单撑安装座	SINGLE SUPPORT MOUNTING BASE	1	
F11-08	57008P370001	单撑安装衬套	SINGLE SUPPORT MOUNTING BUSH	1	
F11-09	57005P380000	单撑安装螺栓	SINGLE SUPPORT MOUNTING BOLT	1	
F11-10	57003P250000	单撑外弹簧	SINGLE SUPPORT OUTER SPRING	1	
F11-11	57004S010000	内弹簧	INNER SPRING	1	
F11-12	58520P380000	中撑焊接组件	MIDDLE SUPPORT WELDING ASSEMBLY	1	
F11-13	169143540000	缓冲橡胶件	CUSHIONING RUBBER PARTS	1	
F11-14	58509P160000	中撑安装螺套	MIDDLE SUPPORT INSTALLATION SCREW SLEEVE	2	
F11-15	57010D010100	单撑弹簧组件	SINGLE SPRING ASSEMBLY	1	
F11-16	58550P380000	中撑弹簧挂板焊接组件	MIDDLE SUPPORT SPRING HANGING PLATE ASSY	1	
F11-17	58508P160000	内六角螺钉	HEXAGON SOCKET SCREW	1	

F12 左踏蹬总成 PEDALING ASSY.

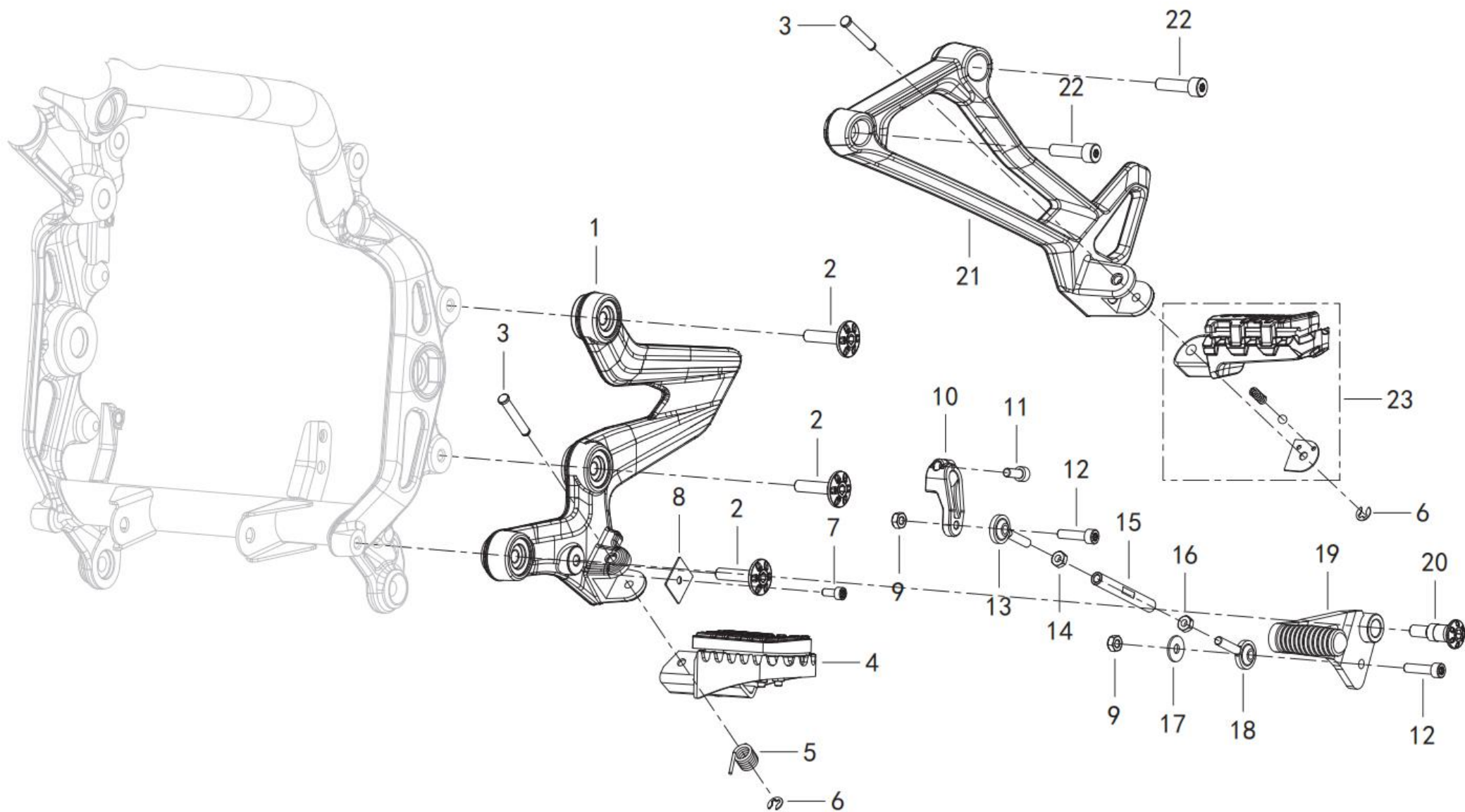

POSITION NO.	CODE	CN DESCRIPTION	EN DESCRIPTION	QTY / UNIT	REMARKS
F12-01	58226P380000	左前脚踏支架	LEFT FRONT PEDAL BRACKET	1	
F12-02	08001P370000	脚踏支架安装螺钉	PEDAL BRACKET MOUNTING SCREW	3	
F12-03	58217P260000	脚踏安装销	PEDAL MOUNTING PIN	2	
F12-04	58220P160002	左前脚踏组合	LEFT FRONT PEDAL COMBINATION	1	
F12-05	58202D010100	直臂扭转弹簧	TORSION SPRING WITH STRAIGHT ARM	1	
F12-06	B0882000050A	挡圈φ5	RETAINING RING Φ FIVE	2	
F12-07	B0226050126S	内六角花形圆柱头螺钉M5×12	HEXAGON SOCKET HEAD CAP SCREW M5×12	1	
F12-08	58256P160000	脚踏限位板	PEDAL STOP PLATE	1	
F12-09	B04810600052	螺母M6×1	NUT M6×1	2	
F12-10	08381P910010	变档杆安装座	SHIFT LEVER MOUNT	1	
F12-11	B0226060166S	内六角花形圆柱头螺钉M6×16	HEXAGON SOCKET HEAD CAP SCREW M6×16	1	
F12-12	B0226060256S	内六角花形圆柱头螺钉M6×25	HEXAGON SOCKET HEAD CAP SCREW M6×25	2	
F12-13	40706S040000	M6左节头	M6 LEFT JOINT	1	
F12-14	08051S040010	左螺母M6	LEFT NUT M6	1	
F12-15	08375P370000	变档杆连接杆	SHIFT LEVER CONNECTING ROD	1	
F12-16	B04800600052	螺母M6-8-ZG	NUT M6-8-ZG	1	
F12-17	B0703000060H	垫圈Φ6	WASHER Φ 6	1	
F12-18	08375S010000	节头	NODAL HEAD	1	
F12-19	08370P180000	换挡踏板组件	PEDAL AS-SHIFT	1	
F12-20	08011L290001	变档杆安装螺栓	SHIFT LEVER MOUNTING BOLTS	1	
F12-21	58266P380000	左后脚踏支架	LEFT REAR PEDAL BRACKET	1	
F12-22	B0226080306S	内六角花形圆柱头螺钉M8×30	HEXAGON SOCKET HEAD CAP SCREW M8×30	2	
F12-23	58260P26000Z	左后脚踏组合	LEFT REAR PEDAL COMBINATION	1	





POSITION NO.	CODE	CN DESCRIPTION	EN DESCRIPTION	QTY / UNIT	REMARKS
F13-01	58246P380001	右前脚踏支架	RIGHT FRONT PEDAL BRACKET	1	
F13-02	08001P370000	脚踏支架安装螺钉	PEDAL BRACKET MOUNTING SCREW	3	
F13-03	58217P260000	脚踏安装销	PEDAL MOUNTING PIN	2	
F13-04	58240P160002	右前踏蹬组件	FRONT RIGHT PEDAL ASSEMBLY	1	
F13-05	58202D010100	直臂扭转弹簧	TORSION SPRING WITH STRAIGHT ARM	1	
F13-06	B0882000050A	挡圈φ5	RETAINING RING Φ 5	2	
F13-07	B0226050126S	内六角花形圆柱头螺钉M5×12	HEXAGON SOCKET HEAD CAP SCREW M5×12	1	
F13-08	58256P160000	脚踏限位板	PEDAL STOP PLATE	1	
F13-09	40702P370000	刹车扭簧	BRAKE TORSION SPRING	1	
F13-10	40710P370000	刹车踏板组件	BRAKE PEDAL ASSEMBLY	1	
F13-11	08011L290001	变档杆安装螺栓	SHIFT LEVER MOUNTING BOLTS	1	
F13-12	B04800600052	螺母M6-8-ZG	NUT M6-8-ZG	1	
F13-13	B0101060252H	六角头螺栓M6×25	HEXAGON HEAD BOLT M6×25	1	
F13-14	B0226060356S	内六角花形圆柱头螺钉M6×35	HEXAGON SOCKET HEAD CAP SCREW M6×35	1	
F13-15	08355S040000	隔套	SPACER SLEEVE	1	
F13-16	40283S010000	节头M6	JOINT HEAD M6	1	
F13-17	B04810600052	螺母M6×1	NUT M6×1	1	
F13-18	B04020600018	薄螺母M6	THIN NUT M6	1	
F13-19	55061M210000	脚泵柱塞螺杆	PLUNGER SCREW OF FOOT PUMP	1	
F13-19	55061P250005	脚泵柱塞螺杆	PLUNGER SCREW OF FOOT PUMP	1	Brembo version
F13-20	B0226060206S	内六角花形圆柱头螺钉M6×20	HEXAGON SOCKET HEAD CAP SCREW M6×20	2	
F13-21	58286P380000	右后脚踏支架	RIGHT REAR PEDAL BRACKET	1	
F13-22	B0226080306S	内六角花形圆柱头螺钉M8×30	HEXAGON SOCKET HEAD CAP SCREW M8×30	2	
F13-23	58280P26000Z	右后踏蹬组合	RIGHT REAR PEDAL COMBINATION	1	

F14 后货架组件 REAR SHELF ASSY.

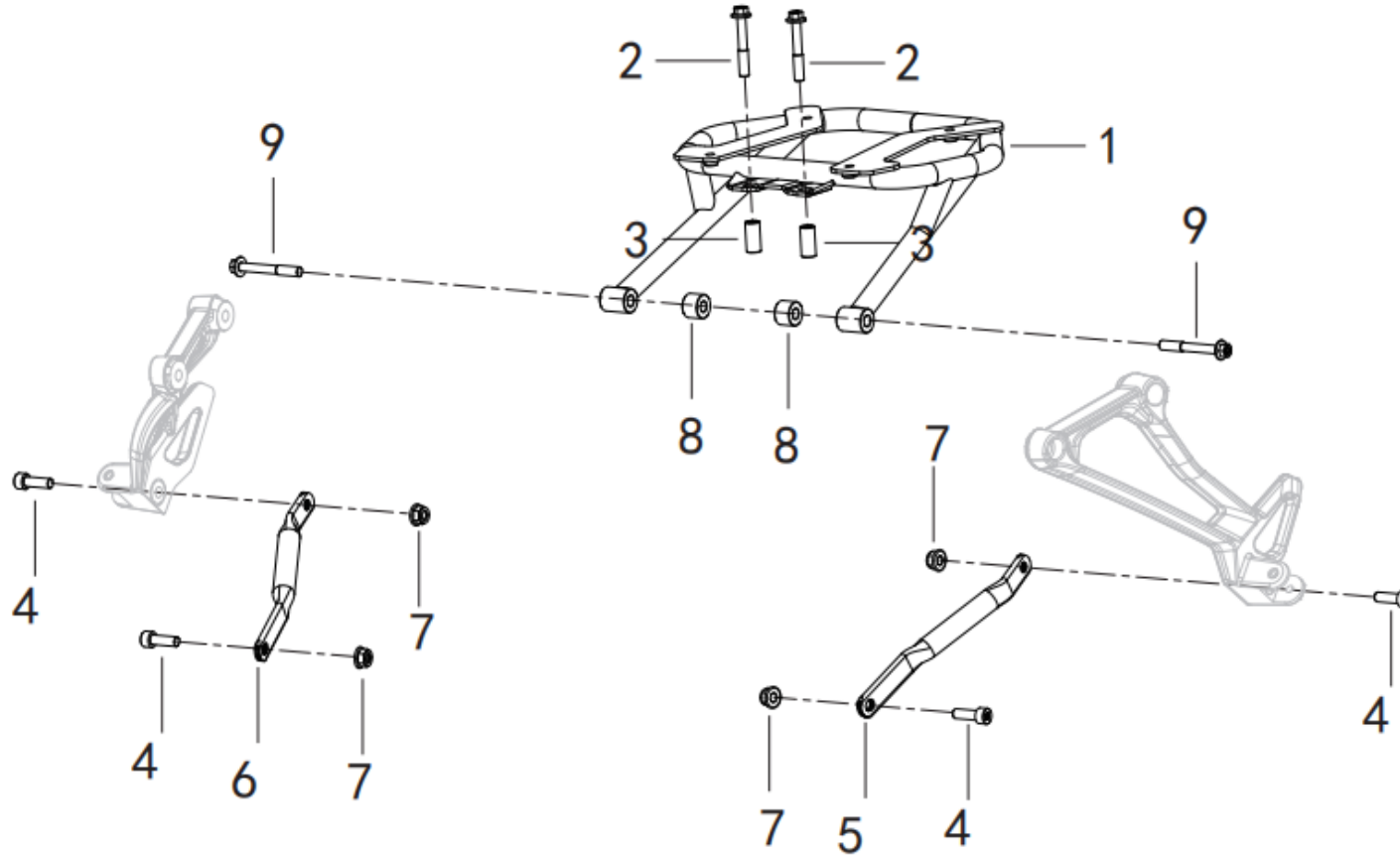

POSITION NO.	CODE	CN DESCRIPTION	EN DESCRIPTION	QTY / UNIT	REMARKS
F14-01	52100P380000	后货架焊接组件	REAR SHELF WELDING ASSEMBLY	1	
F14-02	08014P620007	内六角凹穴螺栓M8×50	HEXAGON SOCKET HEXAGON FLANGE BOLT M8×50	2	
F14-03	57025P380000	单撑安装衬套	BUSH	2	
F14-04	B0226080256S	内六角花形圆柱头螺钉M8×25	HEXAGON SOCKET HEAD CAP SCREW M8×25	4	
F14-05	58860P380000	左边箱支架转接管组件	LEFT BOX BRACKET ADAPTER TUBE ASSEMBLY	1	
F14-06	58870P380000	右边箱支架转接管组件	RIGHT BOX SUPPORT ADAPTER TUBE ASSEMBLY	1	
F14-07	B0417080004H	自锁螺母M8	SELF LOCKING NUT M8	4	
F14-08	52208P380000	边箱固定衬套	SIDE BOX FIXING BUSH	2	
F14-09	08014P620008	内六角凹穴螺栓M8×60	HEXAGON SOCKET HEXAGON FLANGE BOLT M8×60	2	

F15 前照灯 HEADLAMP ASSY.

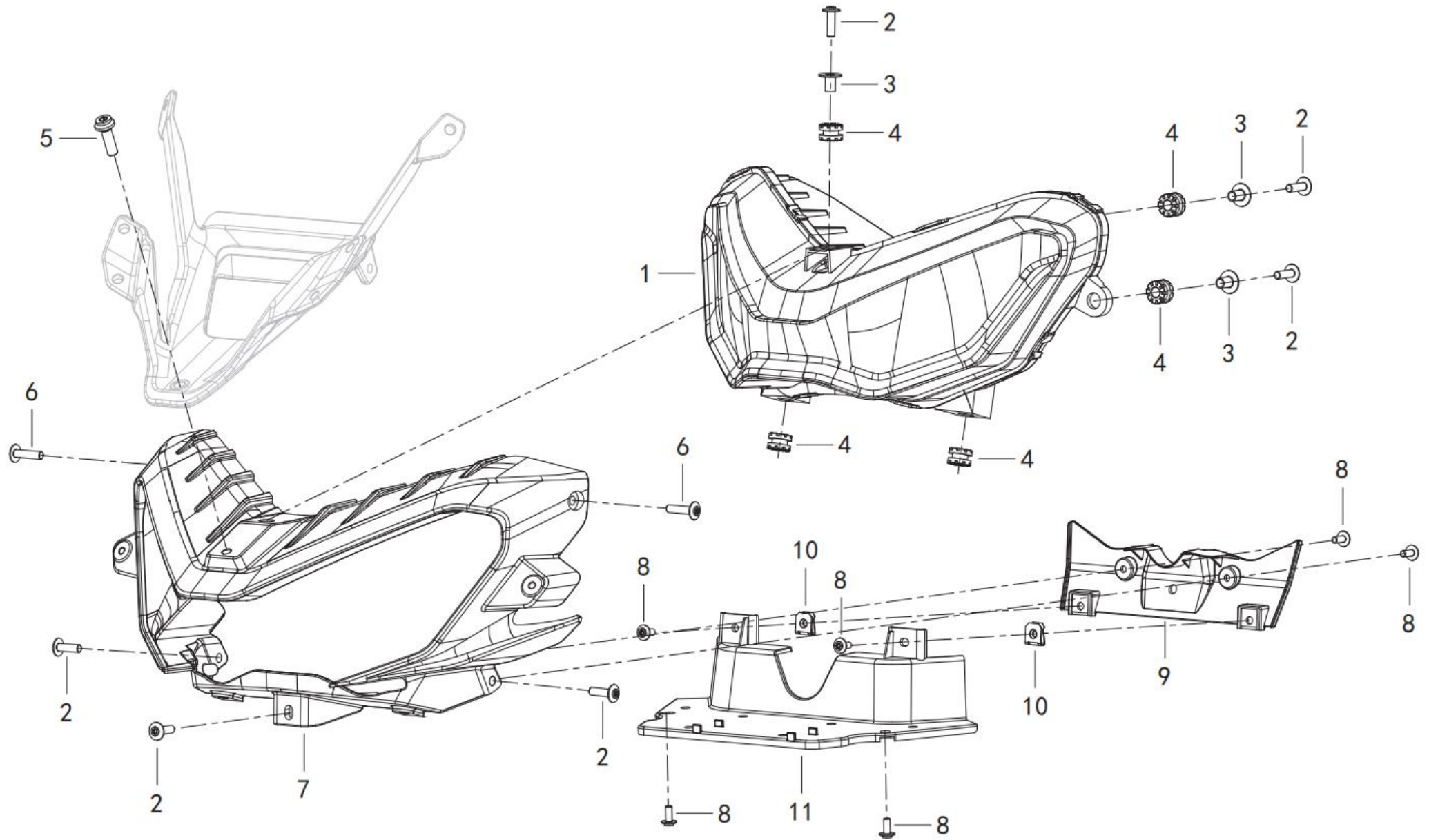

POSITION NO.	CODE	CN DESCRIPTION	EN DESCRIPTION	QTY / UNIT	REMARKS
F15-01	80000P380000	前照灯	HEADLAMP	1	
F15-02	08002P620003	内六角花形法兰面螺钉M6×20	HEXAGON SOCKET FLANGE SCREW M6×20	3	
F15-03	57039P380000	T型衬套	T-TYPE BUSHING	3	
F15-04	70168N290000	仪表缓冲橡胶	INSTRUMENT BUFFER RUBBER	5	
F15-05	08005P620003	六角花形法兰面螺钉M8×25	THIN HEXAGON FLANGE SCREW M8×25	1	
F15-06	08002P620104	内六角花形法兰面螺钉M6×25	HEXAGON SOCKET FLANGE SCREW M6×25	2	
F15-07	08511P380000	大灯支架	HEADLAMP BRACKET	1	
F15-08	08001P620100	内六角花形法兰面螺钉M5×12	HEXAGON SOCKET FLANGE SCREW M5×12	6	
F15-09	65328P380000	大灯后遮光板	REAR LIGHT SHIELD OF HEADLAMP	1	
F15-10	65624P160000	卡螺母M5	CLIP NUT M5	2	
F15-11	65329P380000	大灯下遮光板	UNDER HEADLAMP SHADE	2	



F16 仪表 SPEEDOMETER ASSY.

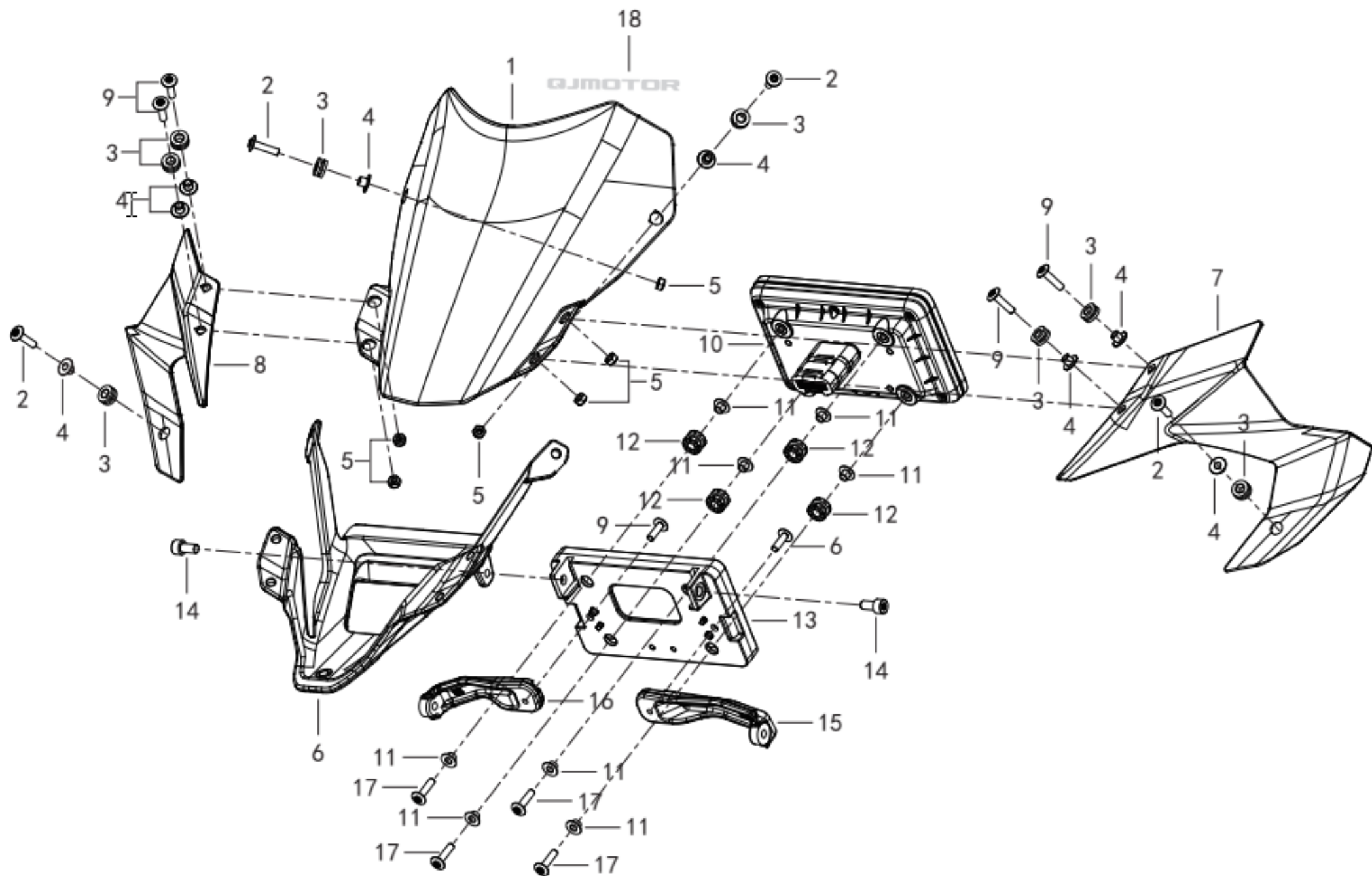

POSITION NO.	CODE	CN DESCRIPTION	EN DESCRIPTION	QTY / UNIT	REMARKS
F16-01	65503P380000	挡风玻璃	WINDSHIELD	1	
F16-02	08002P620103	内六角花形法兰面螺钉M6×20	HEXAGON SOCKET FLANGE SCREW M6×20	4	
F16-03	43038P250000	前转向灯支架橡胶套	RUBBER SLEEVE OF FRONT STEERING LAMP BRACKET	8	
F16-04	53186S010010	隔套	SPACER SLEEVE	8	
F16-05	B04810600052	螺母M6×1	NUT M6×1	6	
F16-06	65521P380000	挡风玻璃支架	WINDSHIELD BRACKET	1	
F16-07	65204P380000	左侧挡风玻璃	LEFT WINDSHIELD	1	
F16-08	65205P380000	右侧挡风玻璃	RIGHT WINDSHIELD	1	
F16-09	08002P620104	内六角花形法兰面螺钉M6×25	HEXAGON SOCKET FLANGE SCREW M6×25	4	
F16-10	70000P380004	仪表总成	INSTRUMENT ASSEMBLY	1	
F16-11	82015S010010	衬套H6	BUSHING H6	8	
F16-12	70168N290000	仪表缓冲橡胶	INSTRUMENT BUFFER RUBBER	4	
F16-13	70068P380000	仪表支架	INSTRUMENT BRACKET	1	
F16-14	B0226080166S	内六角花形圆柱头螺钉M8×16	HEXAGON SOCKET HEAD CAP SCREW M8×16	2	
F16-15	08348P380000	仪表支架左安装板	LEFT MOUNTING PLATE OF INSTRUMENT BRACKET	1	
F16-16	08349P380000	仪表支架右安装板	INSTRUMENT BRACKET RIGHT MOUNTING PLATE	1	
F16-17	08002P620004	内六角花形法兰面螺钉M6×25	HEXAGON SOCKET FLANGE SCREW M6×25	4	
F16-18	05521P380000	车头贴花	HEAD DECAL	1	

F17 前泥板 FRONT FENDER ASSY.

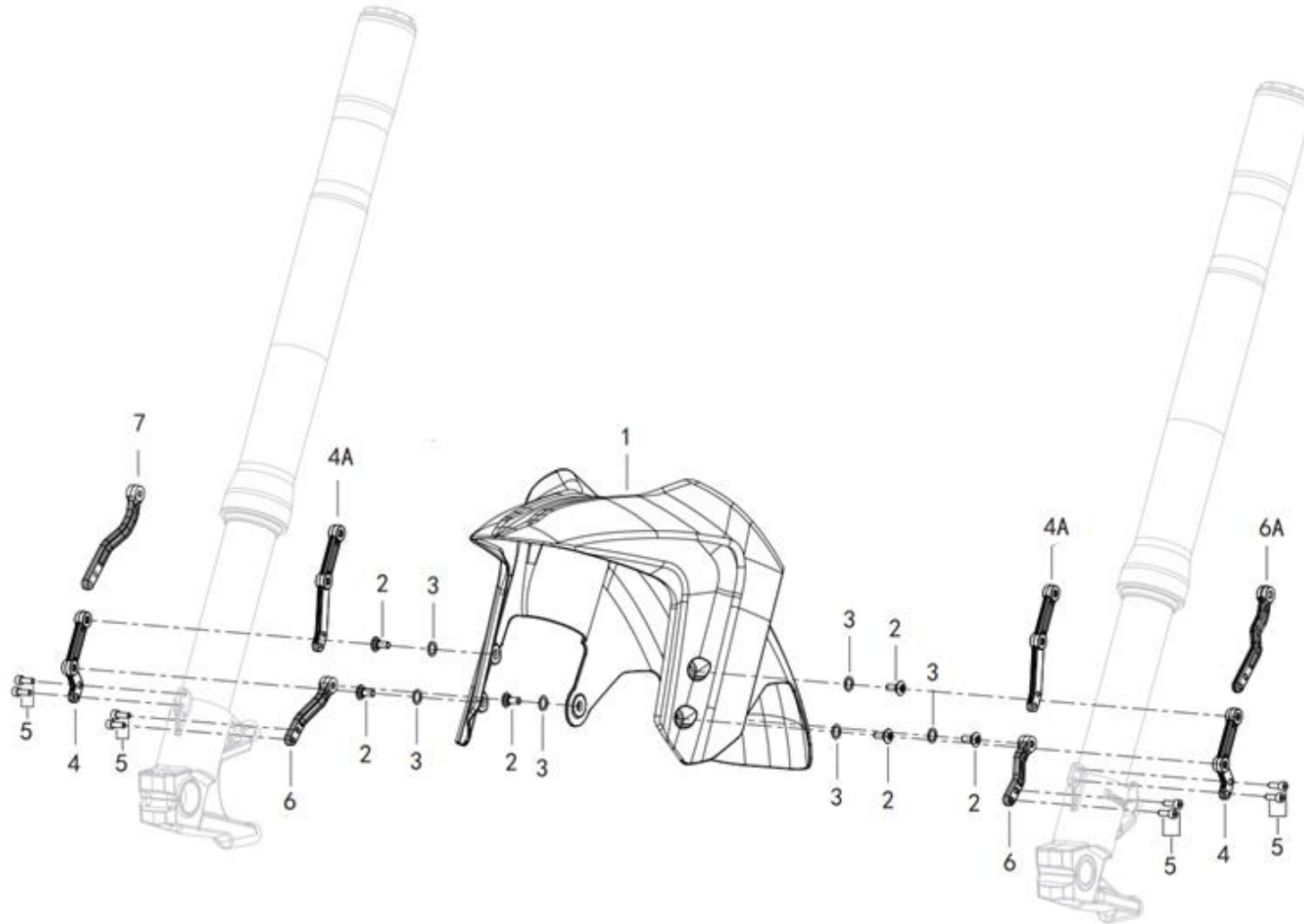

POSITION NO.	CODE	CN DESCRIPTION	EN DESCRIPTION	QTY / UNIT	REMARKS
F17-01	65101P38N600	前挡泥板/哑光059(N6)	FRONT SMALL MUDGUARD II,BLACK N6	1	
F17-02	08003P620100	内六角法兰面台阶螺钉M6×15	SCREW M6×15.2	6	
F17-03	47936S010000	灰色尼龙	GASKET	6	
F17-04A	65141P180003	前泥板前支架	INSTALLATION BOARD	2	
F17-05	B0226050146S	内六角花形圆柱头螺钉M5×14	SCREW M5×0.8×12	8	
F17-06A	65151P380000	前泥板左后支架	LEFT REAR SUPPORT OF FRONT MUD PLATE	1	
F17-07	65152P380000	前泥板右后支架	RIGHT REAR SUPPORT OF FRONT MUD PLATE	1	

F18 前大罩 FRONT COVER ASSY.

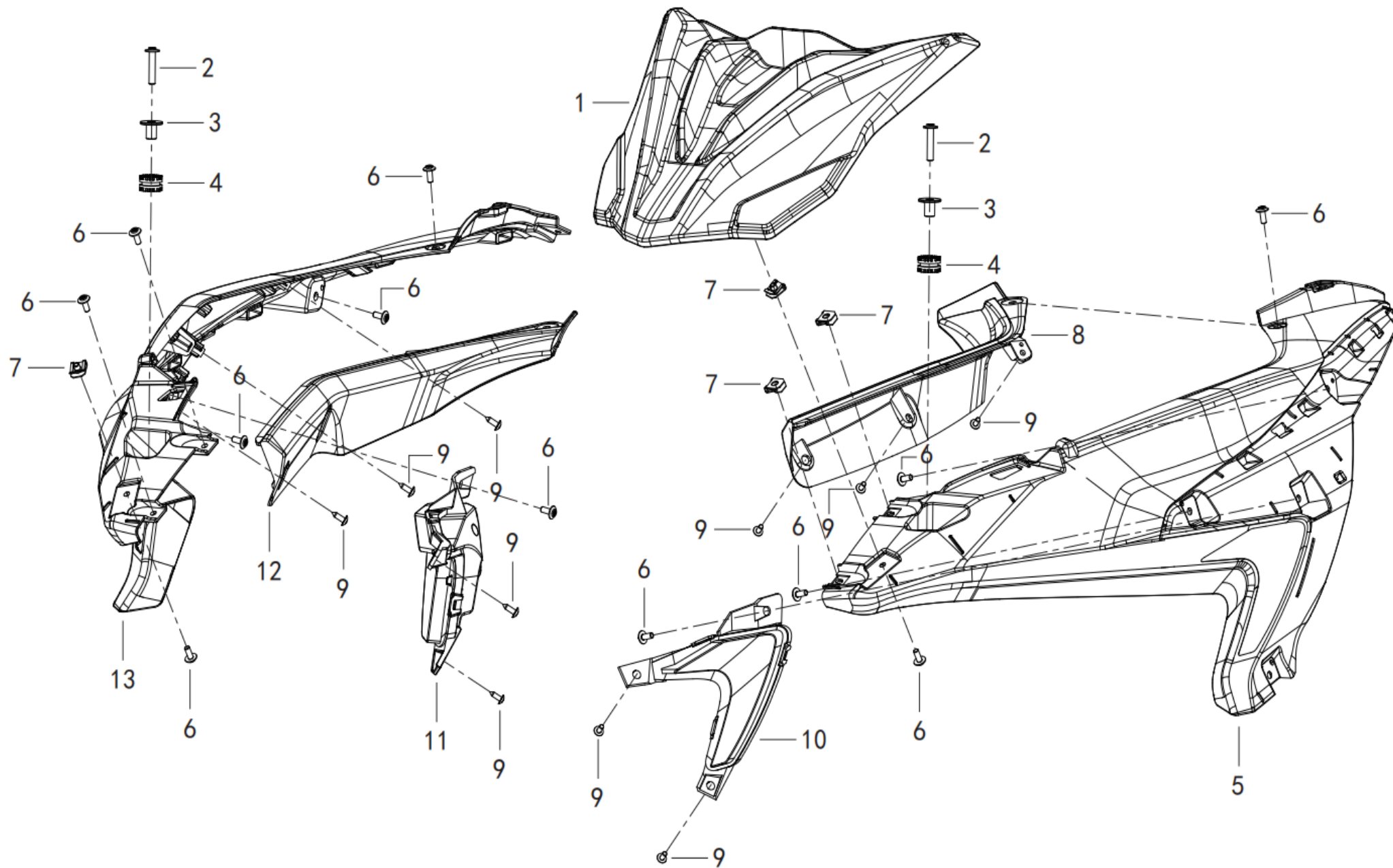

POSITION NO.	CODE	CN DESCRIPTION	EN DESCRIPTION	QTY / UNIT	REMARKS
F18-01	65301P38K600	前大罩面板/蓝色妖姬(K6)	FRONT COVER PANEL,BLUE K6	1	
F18-01	65301P38U400	前大罩面板/哑光深墨绿(U4)	FRONT COVER PANEL,GREEN U4	1	
F18-02	08002P620004	内六角花形法兰面螺钉M6×25	HEXAGON SOCKET FLANGE SCREW M6×25	2	
F18-03	08513P250010	大灯上安装隔套	INSTALL SPACER ON HEADLIGHT	2	
F18-04	65821S010000	橡胶块	RUBBER BLOCK	2	
F18-05	65303P380001	前大罩面板左装饰板	FRONT LARGE COVER PANEL LEFT TRIM PANEL	1	
F18-06	08001P620100	内六角花形法兰面螺钉M5×12	HEXAGON SOCKET FLANGE SCREW M5×12	12	
F18-07	65624P160000	卡螺母M5	CLIP NUT M5	4	
F18-08	65304P380000	左挡板	LEFT BAFFLE	1	
F18-09	B0507420130H	自攻螺钉ST4.2×13	SELF TAPPING SCREW ST4.2×13	1	
F18-10	81100P380000	前左转向灯	FRONT LEFT TURN SIGNAL	1	
F18-11	81300P380000	前右转向灯	FRONT RIGHT TURN SIGNAL	1	
F18-12	65305P380000	右挡板	RIGHT BAFFLE	1	
F18-13	65309P380001	前大罩面板右装饰板	FRONT LARGE COVER PANEL RIGHT TRIM PANEL	1	

F19 油箱护板 FUEL TANK SHIELD ASSY.

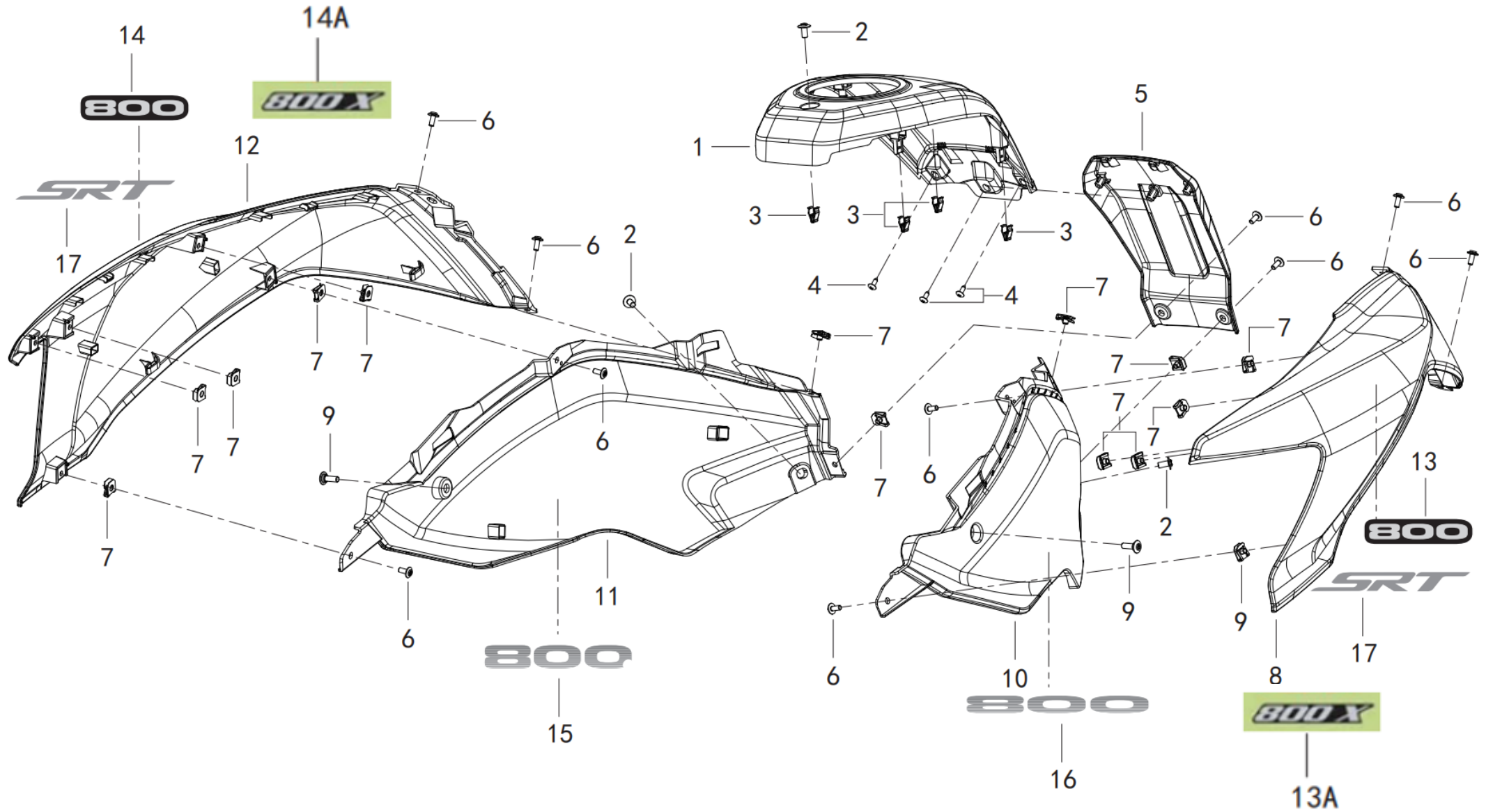

POSITION NO.	CODE	CN DESCRIPTION	EN DESCRIPTION	QTY / UNIT	REMARKS
F19-01	65672P38001Z	油箱中间护板/哑光059(N6)+贴花	MIDDLE GUARD PLATE OF OIL TANK,BLACK N6,WITH STICKER	1	
F19-02	08002P620100	内六角花形法兰面螺钉M6×8	HEXAGON SOCKET FLANGE SCREW M6×8	3	



POSITION NO.	CODE	CN DESCRIPTION	EN DESCRIPTION	QTY / UNIT	REMARKS
F19-03	96037D350000	塑料件卡扣	PLASTIC FASTENER	4	
F19-04	B0507420130H	自攻螺钉ST4.2×13	SELF TAPPING SCREW ST4.2×13	3	
F19-05	65608P380000	座垫前护板	SEAT CUSHION FRONT GUARD	1	
F19-06	08001P620100	内六角花形法兰面螺钉M5×12	HEXAGON SOCKET FLANGE SCREW M5×12	10	
F19-07	65624P160000	卡螺母M5	CLIP NUT M5	14	
F19-08	65673P38005Z	油箱左上护板/蓝色妖姬(K6)+贴花	LEFT UPPER GUARD OF FUEL TANK,BLUE K6,WITH STICKER	1	
F19-08	65673P38008Z	油箱左上护板/哑光深墨绿(U4)+贴花	LEFT UPPER GUARD OF FUEL TANK,GREEN U4,WITH STICKER	1	
F19-09	08004P620000	内六角法兰面台阶螺钉M6×19	HEXAGON SOCKET FLANGE STEP SCREW M6×19	2	
F19-10	65675P38002Z	油箱左下护板/大桥银(C8)+贴花	LEFT LOWER GUARD OF OIL TANK,SILVER C8,WITH STICKER	1	
F19-11	65676P38002Z	油箱右下护板/大桥银(C8)+贴花	RIGHT LOWER GUARD OF OIL TANK,SILVER C8,WITH STICKER	1	
F19-12	65674P38005Z	油箱右上护板/蓝色妖姬(K6)+贴花	RIGHT UPPER GUARD OF OIL TANK,BLUE K6,WITH STICKER	1	
F19-12	65674P38008Z	油箱右上护板/哑光深墨绿(U4)+贴花	RIGHT UPPER GUARD OF OIL TANK,GREEN U4,WITH STICKER	1	
F19-13	05531P380003	油箱左上护板贴花800字样	OIL TANK UPPER LEFT GUARD PLATE DECAL 800 WORDS	1	
F19-13A	05531P380004	油箱左上护板贴花	OIL TANK UPPER LEFT GUARD PLATE DECAL 800 WORDS	1	
F19-14	05532P380003	油箱右上护板贴花800字样	OIL TANK UPPER RIGHT GUARD PLATE DECAL 800 WORDS	1	
F19-14A	05532P380004	油箱右上护板贴花	OIL TANK UPPER RIGHT GUARD PLATE DECAL 800 WORDS	1	
F19-15	05534P38C803	油箱右下护板贴花/800字样/配大桥银(C8)	DECAL ON RIGHT LOWER GUARD PLATE OF OIL TANK	1	
F19-16	05533P38C803	油箱左下护板贴花/800字样/配大桥银(C8)	DECAL ON LEFT LOWER GUARD PLATE OF OIL TANK	1	
F19-17	05514P380000	左右护板标牌/SRT	LEFT AND RIGHT GUARD PLATE SIGNS,SRT	2	

## F20 风扇导风罩 FAN AIR HOOD

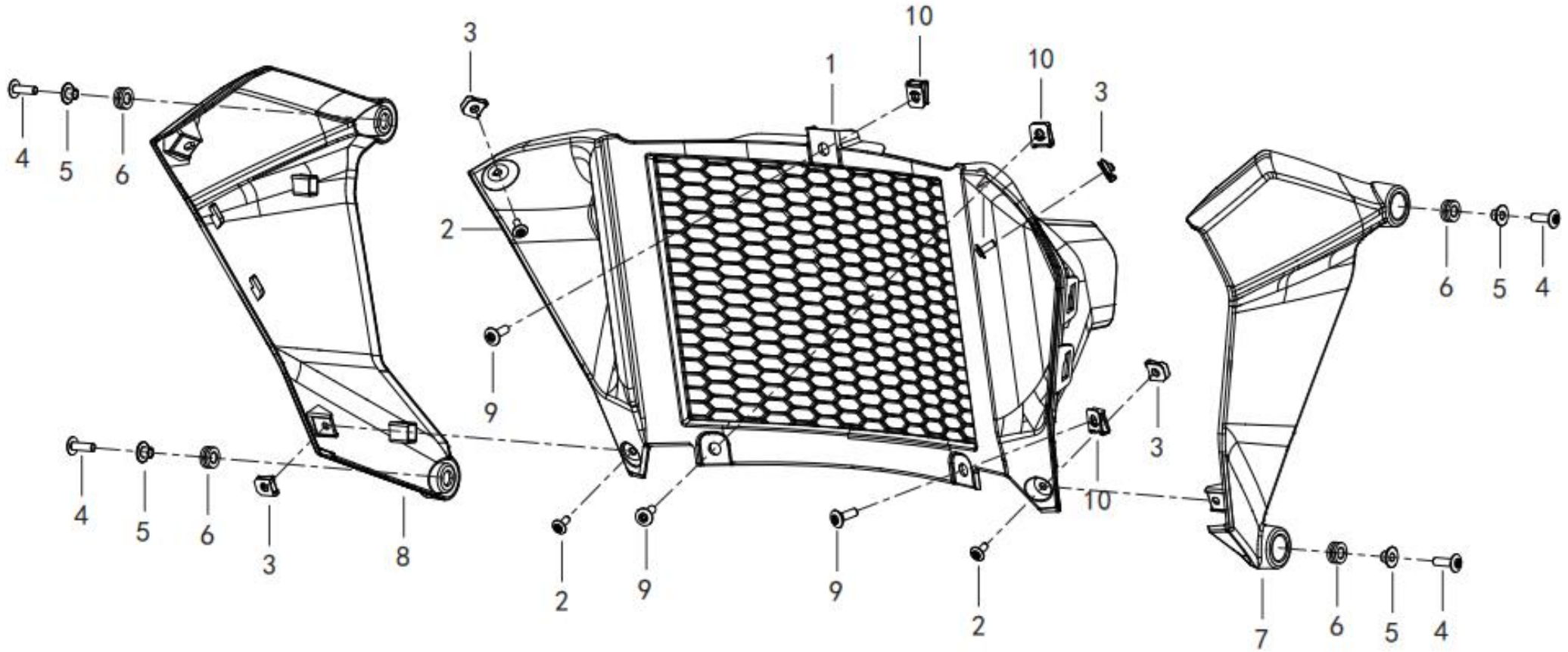

POSITION NO.	CODE	CN DESCRIPTION	EN DESCRIPTION	QTY / UNIT	REMARKS
F20-01	65681P380000	散热器前导流板	LEFT REAR GUARD	1	
F20-02	08001P620100	内六角花形法兰面螺钉M5×12	HEXAGON SOCKET FLANGE SCREW M5×12	4	
F20-03	65624P160000	卡螺母M5	CLIP NUT M5	4	
F20-04	08002P620103	内六角花形法兰面螺钉M6×20	HEXAGON SOCKET FLANGE SCREW M6×20	4	
F20-05	53186S010010	隔套	SPACER SLEEVE	4	
F20-06	43038P250000	前转向灯支架橡胶套	RUBBER SLEEVE OF FRONT STEERING LAMP BRACKET	4	
F20-07	65632P38C800	左前护板/大桥银(C8)	LEFT FRONT GUARD,SILVER C8,WITHOUT STICKER	1	
F20-08	65633P38C800	右前护板/大桥银(C8)	RIGHT FRONT GUARD,SILVER C8,WITHOUT STICKER	1	
F20-09	08004P620000	内六角法兰面台阶螺钉M6×19	HEXAGON SOCKET FLANGE STEP SCREW M6×19	3	
F20-10	65803S010010	卡片螺母M6	CARD NUT M6	3	

F21 护板 SIDE COVER ASSY.

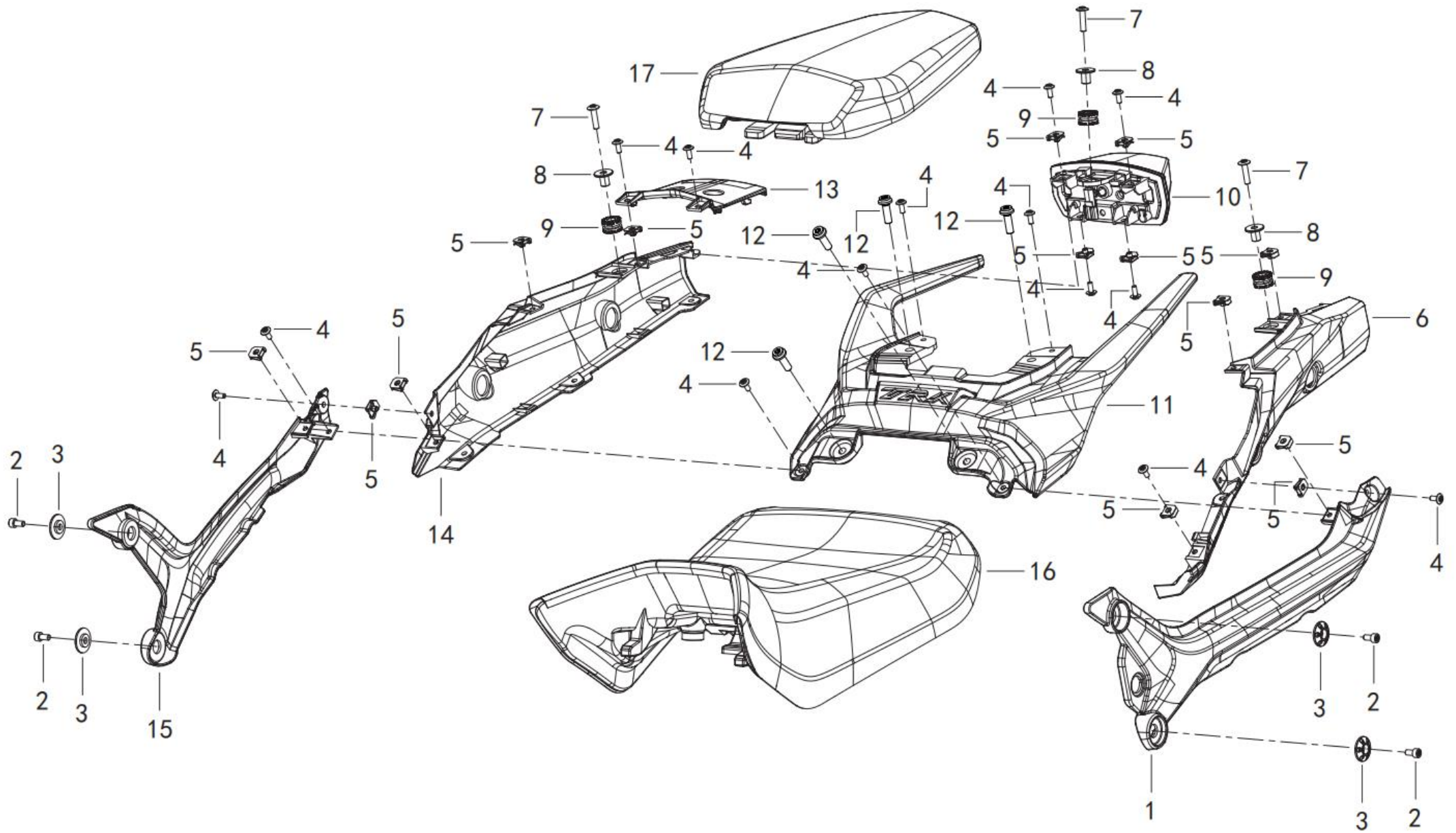

POSITION NO.	CODE	CN DESCRIPTION	EN DESCRIPTION	QTY / UNIT	REMARKS
F21-01	65601P38N600	左护板/哑光059(N6)	LEFT GUARD,BLACK N6	1	
F21-02	B0226060126S	内六角花形圆柱头螺钉M6×12	HEXAGON SOCKET HEAD CAP SCREW M6×12	4	
F21-03	65627P380000	护板安装衬套	GUARD MOUNTING BUSH	4	
F21-04	08001P620100	内六角花形法兰面螺钉M5×12	HEXAGON SOCKET FLANGE SCREW M5×12	14	
F21-05	65624P160000	卡螺母M5	CLIP NUT M5	14	
F21-06	65901P380000	左尾罩	LEFT TAIL COVER	1	
F21-07	08002P620004	内六角花形法兰面螺钉M6×25	HEXAGON SOCKET FLANGE SCREW M6×25	3	
F21-08	08513P250010	大灯上安装隔套	INSTALL SPACER ON HEADLIGHT	3	
F21-09	65821S010000	橡胶块	RUBBER BLOCK	3	
F21-10	82000P380000	尾灯	TAILLIGHT	1	
F21-11	52002P38C800	后扶手	REAR ARMREST	1	
F21-12	08005P620003	六角花形法兰面螺钉M8×25	THIN HEXAGON FLANGE SCREW M8×25	4	
F21-13	65912P380000	尾罩后连接板	REAR CONNECTING PLATE OF TAIL COVER	2	
F21-14	65902P380000	右尾罩	RIGHT TAIL COVER	1	
F21-15	65602P38N600	右护板/哑光059(N6)	RIGHT GUARD,BLACK N6	6	
F21-16	51100P380000	前座垫组件	CUSHION AS-FRONT	1	
F21-17	51200P380000	后座垫组件	CUSHION AS-REAR SEAT	1	

F22 后泥板 FENDER ASSY.

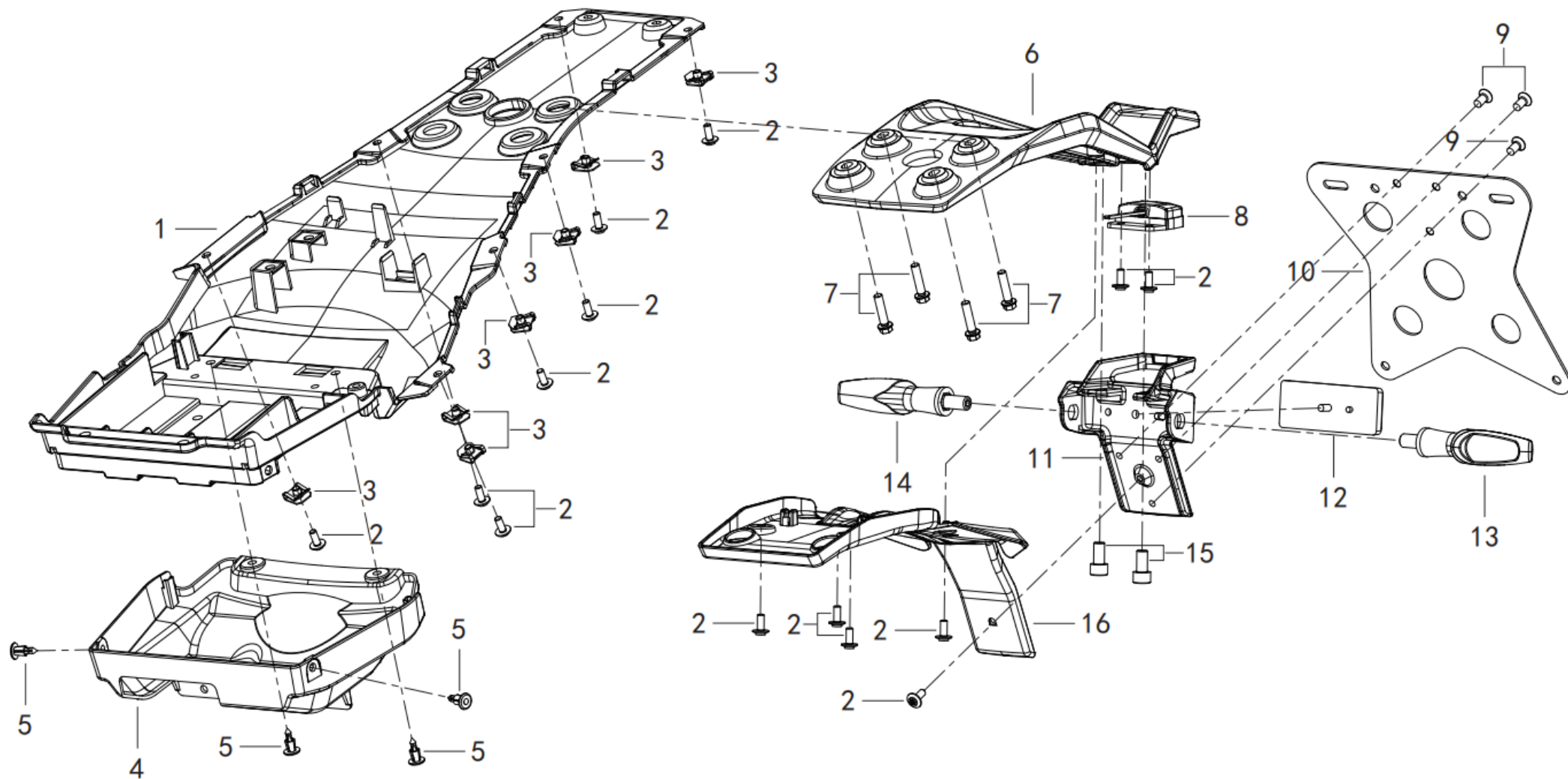



POSITION NO.	CODE	CN DESCRIPTION	EN DESCRIPTION	QTY / UNIT	REMARKS
F22-01	65701P380000	后挡泥板	REAR FENDER	1	
F22-02	08001P620100	内六角花形法兰面螺钉M5×12	HEXAGON SOCKET FLANGE SCREW M5×12	14	
F22-03	65624P160000	卡螺母M5	CLIP NUT M5	7	
F22-04	65732P380000	整流器装饰罩	RECTIFIER DECORATIVE COVER	1	
F22-05	65850K140000	膨胀螺钉组件	EXPANSION SCREW ASSEMBLY	4	
F22-06	65771P380000	后挡泥板支架	REAR FENDER BRACKET	1	
F22-07	160306030050	六角内梅花螺栓	HEXAGON INNER RING BOLT M6×25	4	
F22-08	82900P370000	牌照灯	LICENSE PLATE LAMP	1	
F22-09	B0201060122H	螺钉M6×12	SCREW M6×12	3	
F22-10	65773P380000	后牌照安装版	REAR LICENSE PLATE INSTALLATION	1	
F22-11	65772P380000	牌照安装座	LICENSE PLATE MOUNT	1	
F22-12	86500T030001	后反射体组件	REAR REFLECTOR ASSEMBLY	1	
F22-13	81500P380000	后左转向灯	REAR LEFT TURN SIGNAL	1	
F22-14	81700P380000	后右转向灯	REAR RIGHT TURN SIGNAL	1	
F22-15	B0226080166S	内六角花形圆柱头螺钉M8×16	HEXAGON SOCKET HEAD CAP SCREW M8×16	2	
F22-16	65741P380000	后挡泥板后部	REAR OF REAR FENDER	1	



F23 冷却系统 COOLING SYSTEM ASSY.

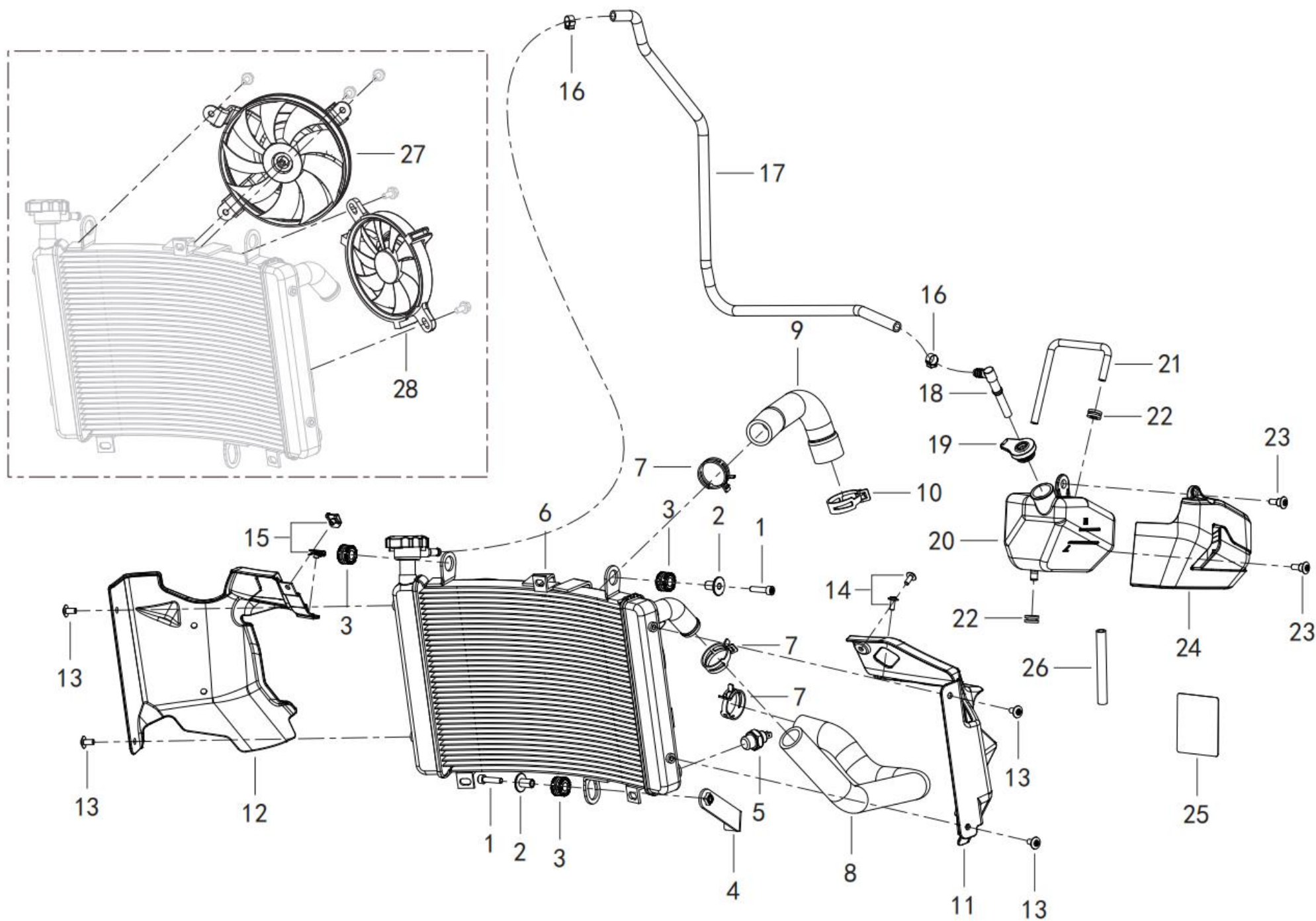

POSITION NO.	CODE	CN DESCRIPTION	EN DESCRIPTION	QTY / UNIT	REMARKS
F23-01	B0226060256S	内六角花形圆柱头螺钉M6×25	HEXAGON SOCKET HEAD CAP SCREW M6×25	2	
F23-02	59452P250100	散热器安装隔套	RADIATOR MOUNTING SPACER	2	
F23-03	65821S010000	橡胶块	RUBBER BLOCK	3	
F23-04	59540P370000	水箱支撑座	WATER TANK SUPPORT	1	
F23-05	279115050000	出水温开关组件	OUTLET WATER TEMPERATURE SWITCH ASSEMBLY	1	
F23-06	279126060090	水箱组件	WATER TANK ASSEMBLY	1	
F23-07	06103P160100	水管板式卡箍Φ32	WATER PIPE PLATE CLAMP Φ 32	3	
F23-08	06250P290000	发动机出水管组件	ENGINE WATER OUTLET PIPE ASSEMBLY	1	
F23-09	06211P380000	发动机进水管	ENGINE WATER INLET PIPE	1	
F23-10	279326060010	板式卡箍35	PLATE CLAMP 35	1	
F23-11	65682P380000	散热器左挡风板	RADIATOR LEFT WINDSHIELD	1	
F23-12	65683P380000	散热器右挡风板	RADIATOR RIGHT WINDSHIELD	1	
F23-13	08002P620000	内六角花形法兰面螺钉M6×8	HEXAGON SOCKET FLANGE SCREW M6×8	4	
F23-14	08001P620000	内六角花形法兰面螺钉M5×12	HEXAGON SOCKET FLANGE SCREW M5×12	2	
F23-15	65624P160000	卡螺母M5	CLIP NUT M5	2	
F23-16	50376S010000	卡箍Φ10	CLAMP Φ 10	2	
F23-17	06105P370000	水壶与水箱连接管	CONNECTING PIPE BETWEEN KETTLE & WATER TANK	1	
F23-18	14039S040000	水管	WATER PIPE	1	
F23-19	14030S040000	副水箱盖	AUXILIARY WATER TANK COVER	1	
F23-20	06111P370000	膨胀水壶	EXPANSION KETTLE	1	
F23-21	06101P370000	膨胀水壶出水管	OUTLET PIPE OF EXPANSION KETTLE	1	
F23-22	43038P250000	前转向灯支架橡胶套	RUBBER SLEEVE OF FRONT STEERING LAMP BRACKET	1	
F23-23	08004P380100	内六角法兰面台阶螺钉M6×19	HEXAGON SOCKET FLANGE STEP SCREW M6×19	2	
F23-24	06112P370000	膨胀水壶装饰盖	DECORATIVE COVER OF EXPANSION KETTLE	1	
F23-25	06228P250000	水管隔热锡箔纸	TIN FOIL FOR HEAT INSULATION OF WATER PIPE	1	
F23-26	06226P250000	溢流管	OVERFLOW PIPE	1	
F23-27	279026350000	风扇组件1	FAN ASSEMBLY 1	1	
F23-28	270144410000	风扇	FAN	1	

F24 电器| ELECTRICAL EQUIPMENT ASSY.

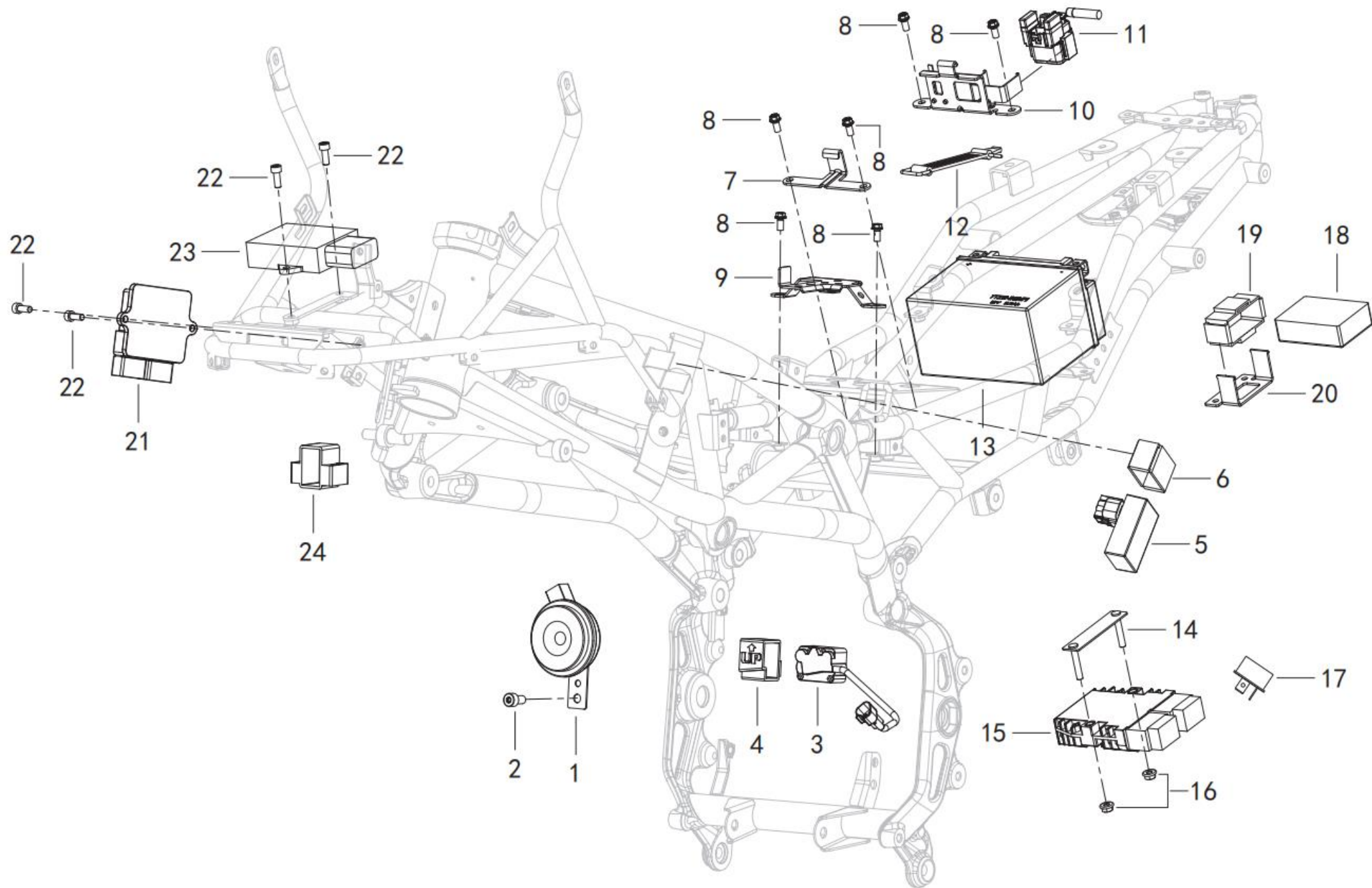

POSITION NO.	CODE	CN DESCRIPTION	EN DESCRIPTION	QTY / UNIT	REMARKS
F24-01	95100P180000	喇叭	HORN	1	
F24-02	B0226080166S	内六角花形圆柱头螺钉M8×16	HEXAGON SOCKET HEAD CAP SCREW M8×16	1	
F24-03	91210N300000	侧翻开关	ROLLOVER SWITCH	1	
F24-04	98901S010000	传感器橡胶	SENSOR RUBBER	1	
F24-05	97710P290000	仪表升压电源模块	INSTRUMENT BOOST POWER SUPPLY MODULE	1	
F24-06	96007B720000	点火器套	IGNITER SLEEVE	1	
F24-07	57041P380000	电瓶绑带挂钩	BATTERY STRAP HOOK	1	
F24-08	160306030010	六角内梅花螺栓	HEXAGON INNER RING BOLT M6×12	6	
F24-09	59510P380000	布线安装座	WIRING MOUNT	1	
F24-10	58820P380000	电瓶压板组件	BATTERY PRESSURE PLATE ASSEMBLY	1	
F24-11	94000S010000	起动继电器	START RELAY	1	
F24-12	96020T750000	电瓶绑带	BATTERY STRAP	1	
F24-13	AC-TTZ14S (HW)	电瓶	BATTERY VRLA 12V11.2 AH/10HR	1	
F24-14	58790P380000	整流器安装座	RECTIFIER MOUNTING BASE	2	
F24-15	299066570000	整流器	RECTIFIER	1	
F24-16	B0407060005H	六角法兰面螺母M6	HEXAGON FLANGE NUT M6	2	
F24-17	96700K060000	启动二极管	STARTING DIODE	2	
F24-18	92150P090000	电容组件	CAPACITOR ASSEMBLY	1	
F24-19	92151P090000	电容组件安装护套	CAPACITOR ASSEMBLY MOUNTING SHEATH	1	
F24-20	59521P380000	电容安装板	CAPACITOR MOUNTING PLATE	1	
F24-21	96C00U351000	ECU	ECU	1	
F24-22	B0226060166S	内六角花形圆柱头螺钉M6×16	HEXAGON SOCKET HEAD CAP SCREW M6×16	4	
F24-23	96J00P380000	中控器	CENTRAL CONTROLLER	1	
F24-24	96011N290000	控制器护套	CONTROLLER SHEATH	1	



F25 电器II ELECTRICAL EQUIPMENT ASSY.

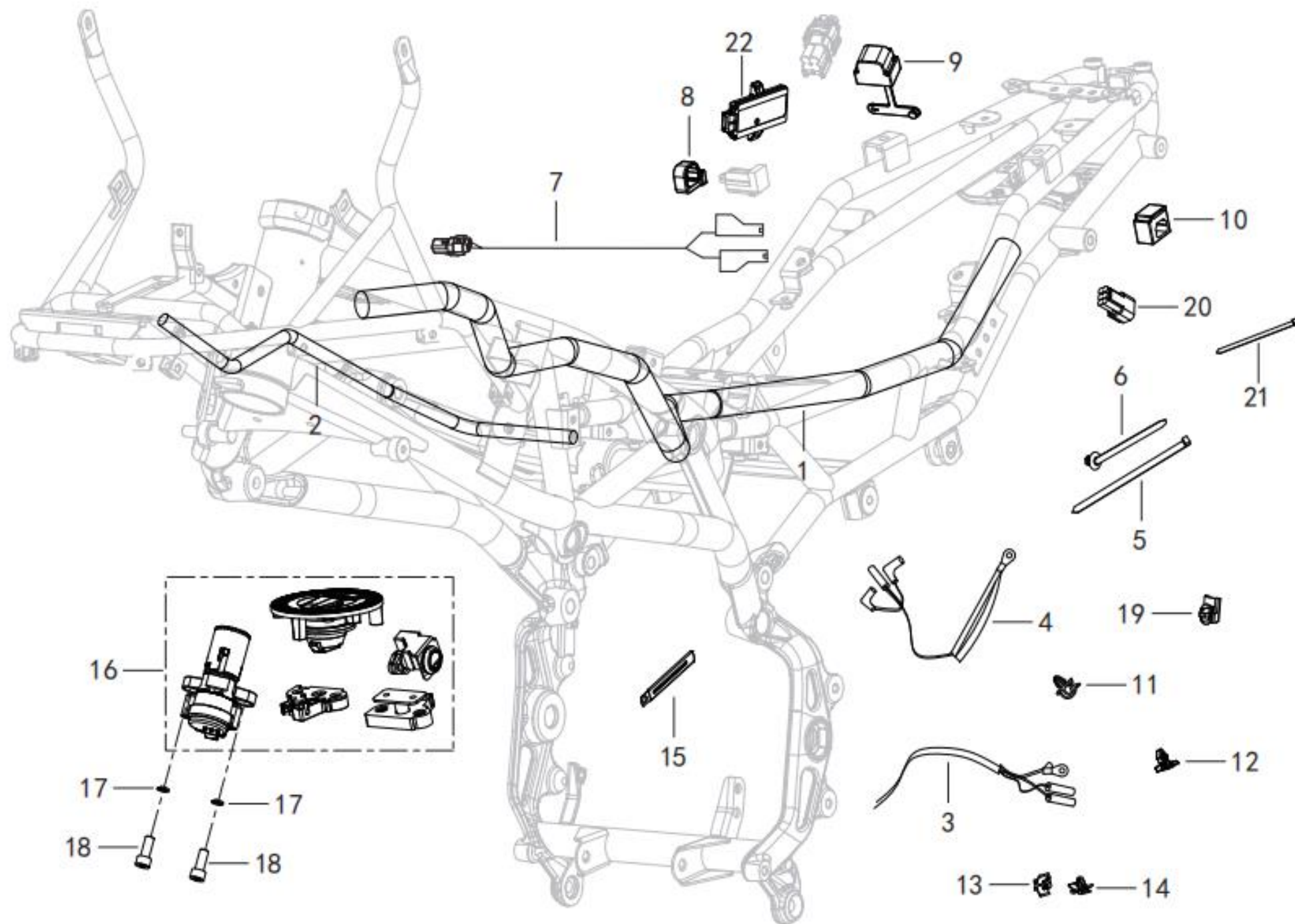



POSITION NO.	CODE	CN DESCRIPTION	EN DESCRIPTION	QTY / UNIT	REMARKS
F25-01	92050P380003	主线束总成	CABLE ASSEMBLY	1	
F25-02	92070P380002	发动机线束	ENGINE HARNESS ASSEMBLY	1	
F25-03	92300P370000	马达线	MOTOR LINE	1	
F25-04	92500P380000	搭铁线	GROUND WIRE	1	
F25-05	40098B450000	绑扎带	BANDAGE	15	
F25-06	96001P360000	螺纹绑带	THREAD TIE	10	
F25-07	92360P320001	前刹车开关转接线	FRONT BRAKE SWITCH ADAPTER	1	
F25-08	57041P410000	ECU检查插口安装橡胶	ECU CHECK SOCKET MOUNTING RUBBER	1	
F25-09	57042P410000	ABS检查插口安装橡胶	ABS INSPECTION SOCKET INSTALLATION RUBBER	1	
F25-10	57043P410000	后牌照灯插件安装橡胶	INSTALLATION RUBBER OF REAR LICENSE PLATE LAMP PLUG-IN	1	
F25-11	65831P180000	管夹A097	PIPE CLAMP ZT-35	3	
F25-12	92928P290000	氧传感器接插件卡子	OXYGEN SENSOR CONNECTOR CLIP	2	
F25-13	96031N350000	卡扣1.5系列	BUCKLE 1.5 SERIES	6	
F25-14	96032N350000	卡扣2.3系列	CLASP 2.3 SERIES	5	
F25-15	58430J000000	线夹组件	CLAMP ASSEMBLY	4	
F25-16	88000P380000	套锁	SET LOCK	1	
F25-17	B0700000080H	弹簧垫圈8	SPRING WASHER 8	2	
F25-18	B0226080206S	内六角花形圆柱头螺钉M8×20	HEXAGON SOCKET HEAD CAP SCREW M8×20	2	
F25-19	96035P160000	ABS诊断仪卡扣	ABS DIAGNOSTIC INSTRUMENT BUCKLE	1	
F25-20	92059P060000	智控器对插件	INTELLIGENT CONTROLLER TO PLUG-IN	1	
F25-21	96003P360000	尼龙扎线带	NYLON CABLE TIES	10	

F26 发动机附件 ENGINE ATTACHMENT ASSY.

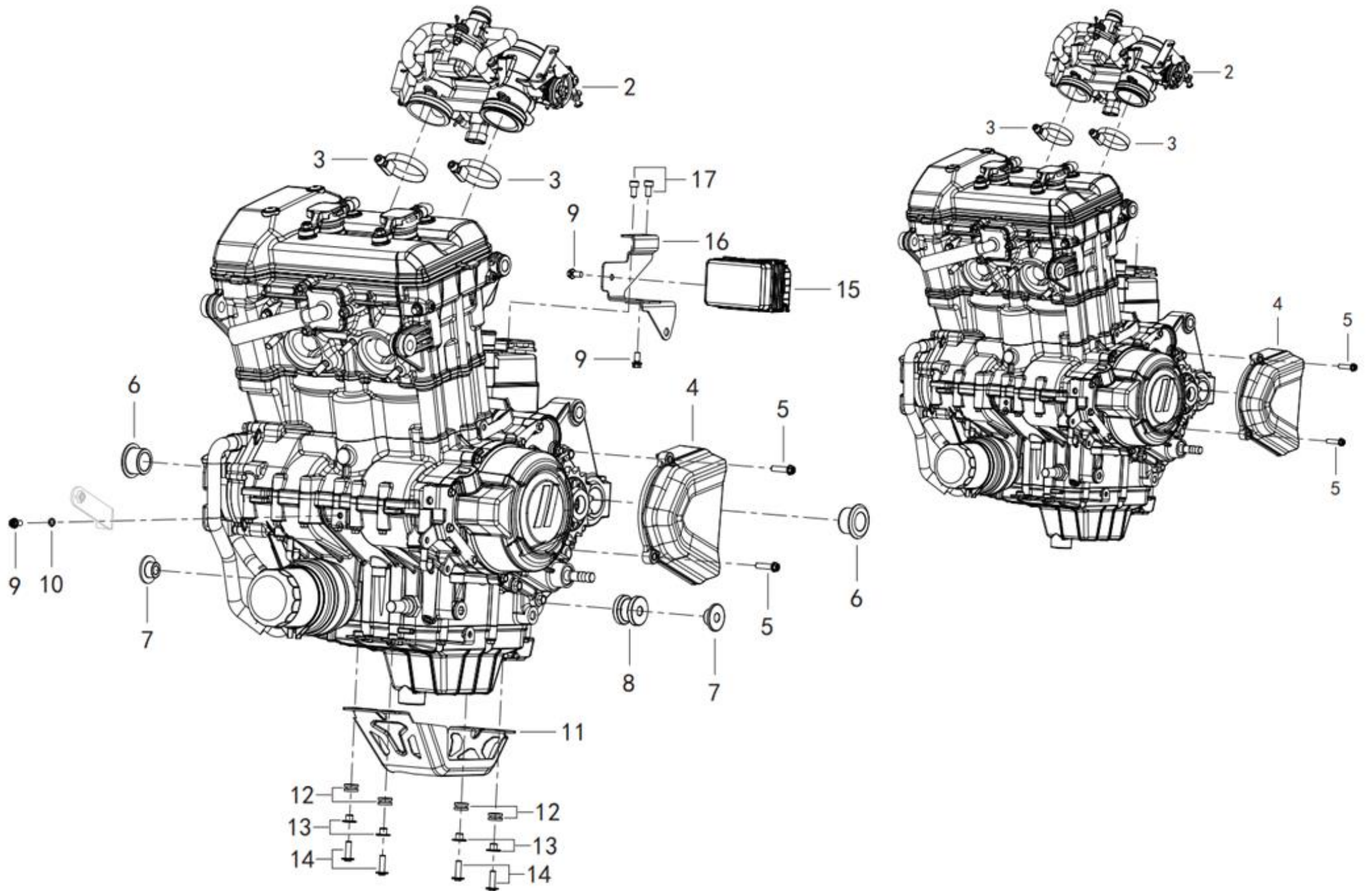

POSITION NO.	CODE	CN DESCRIPTION	EN DESCRIPTION	QTY / UNIT	REMARKS
F26-02	289006060020	节流阀体组件	THROTTLE BODY ASSEMBLY	1	
F26-03	280426030000	卡箍组件	CLAMP AS	2	
F26-04	210276060020	输出链轮盖	OUTPUT SPROCKET COVER	1	
F26-05	160306030050	六角内梅花螺栓M6×25	HEXAGON INNER RING BOLT M6×25	2	
F26-06	53013P370000	后摆臂安装衬套	REAR SWING ARM MOUNTING BUSH	2	
F26-07	53116P300100	发动机后下安装衬套	ENGINE REAR LOWER MOUNTING BUSH	2	
F26-08	57026P290000	发动机中间轴套	ENGINE INTERMEDIATE SHAFT SLEEVE	1	
F26-09	160306030010	六角内梅花螺栓	HEXAGON INNER RING BOLT M6×12	3	
F26-10	B0700000060H	弹簧垫圈Φ6	SPRING WASHER Φ 6	1	
F26-11	65407P380000	发动机防护罩	ENGINE GUARD	1	
F26-12	43038P250000	前转向灯支架橡胶套	RUBBER SLEEVE OF FRONT STEERING LAMP BRACKET	4	
F26-13	53186S010010	隔套	SPACER SLEEVE	4	
F26-14	08002P620103	内六角花形法兰面螺钉M6×20	HEXAGON SOCKET FLANGE SCREW M6×20	4	
F26-15	45700P160000	双通道ABS总成	DUAL CHANNEL ABS ASSEMBLY	1	
F26-16	58560P370000	ABS安装座	ABS MOUNT	1	
F26-17	B0226060126S	内六角花形圆柱头螺钉M6×12	HEXAGON SOCKET HEAD CAP SCREW M6×12	2	

F27 保险杠组件 BUMPER ASSY.

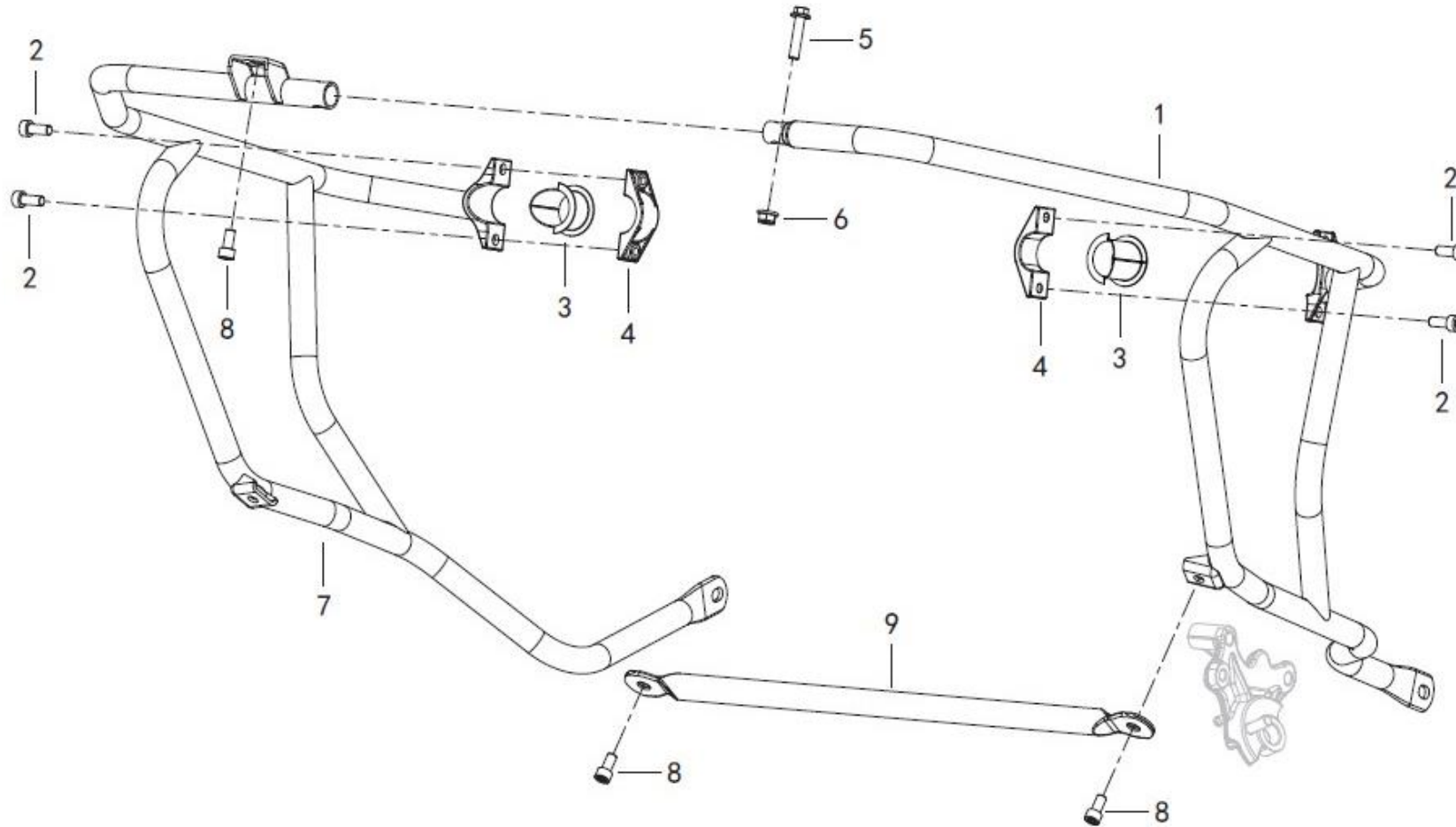

POSITION NO.	CODE	CN DESCRIPTION	EN DESCRIPTION	QTY / UNIT	REMARKS
F27-01	59110P380000	前左保险杠组件	FRONT LEFT BUMPER ASSEMBLY	1	
F27-02	B0226080306S	内六角花形圆柱头螺钉M8×30	HEXAGON SOCKET HEAD CAP SCREW M8 × 30	4	
F27-03	59109P380000	保险杠橡胶套	BUMPER RUBBER SLEEVE	2	
F27-04	59004P380000	保险杠安装座II	BUMPER MOUNT II	2	
F27-05	B0226080356S	内六角花形圆柱头螺钉M8×35	HEXAGON SOCKET HEAD CAP SCREW M8 × 35	2	
F27-06	B0417080004H	自锁螺母M8	SELF LOCKING NUT M8	2	
F27-07	59120P380000	前右保险杠组件	FRONT RIGHT BUMPER ASSEMBLY	1	
F27-08	B0226080166S	内六角花形圆柱头螺钉M8×16	HEX SOCKET TORX CHEESE HEAD SCREW M8x16	3	
F27-09	59108P380000	保险杠左右连接管	LEFT AND RIGHT CONNECTING PIPES OF BUMPER	1	

E01 CYLINDER COVER ASSEMBLY(缸盖罩分总成)

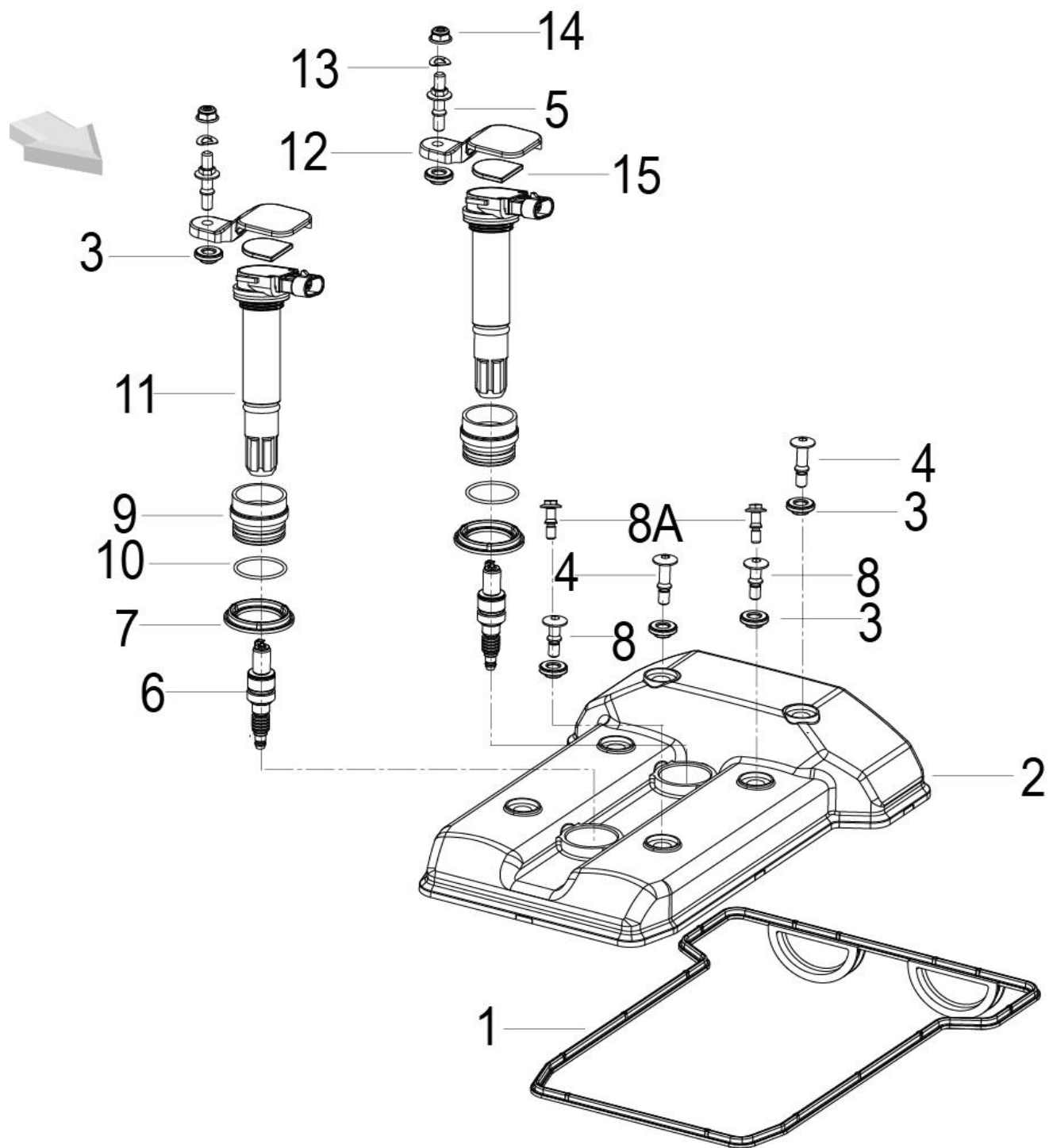



POSITION NO.	CODE	CN DESCRIPTION	EN DESCRIPTION	QTY / UNIT	REMARKS
E01-01	109026060000	气缸盖罩密封垫	CYLINDER HEAD COVER GASKET	1	
E01-02	16910606BG00	气缸盖罩(哑黑)	CYLINDER HEAD COVER	1	
E01-03	100086090000	螺钉密封橡胶	SCREW SEAL RUBBER	6	
E01-04	100016060100	缸盖罩固定螺栓M6×29.5	CYLINDER HEAD COVER BOLT M6×29.5	2	
E01-05	100106090100	螺栓M6×39	CYLINDER HEAD COVER BOLT M6×39	2	
E01-06	299073160000	火花塞	SPARK PLUG	2	
E01-07	100076090000	火花塞槽垫	SPARK PLUG CUSHION	2	
E01-08	100116090001	缸盖罩固定螺栓M6×23.5	CYLINDER HEAD COVER SCREW M6×23.5	2	
E01-08A	100116090001	缸盖罩螺栓	CYLINDER HEAD COVER SCREW	2	
E01-09	100286030000	高压包套	STICK COIL CAP	2	
E01-10	B190102650B0	O型圈26.5×1.8	O RING 26.5×1.8	2	
E01-11	96200P250000	笔式高压包	IGNITION COIL	2	
E01-12	10006606BG00	线圈定位夹(哑黑)	COIL POSITIONING CLIP	2	
E01-13	290026090000	波形垫片	WAVE WASHER	2	
E01-14	B04810600052	线夹自锁螺母M6×1	NUT M6×1	2	
E01-15	290026060000	线圈安全橡胶	COIL SAFETY RUBBER	2	

E02 CYLINDER HEAD(气缸盖分总成)

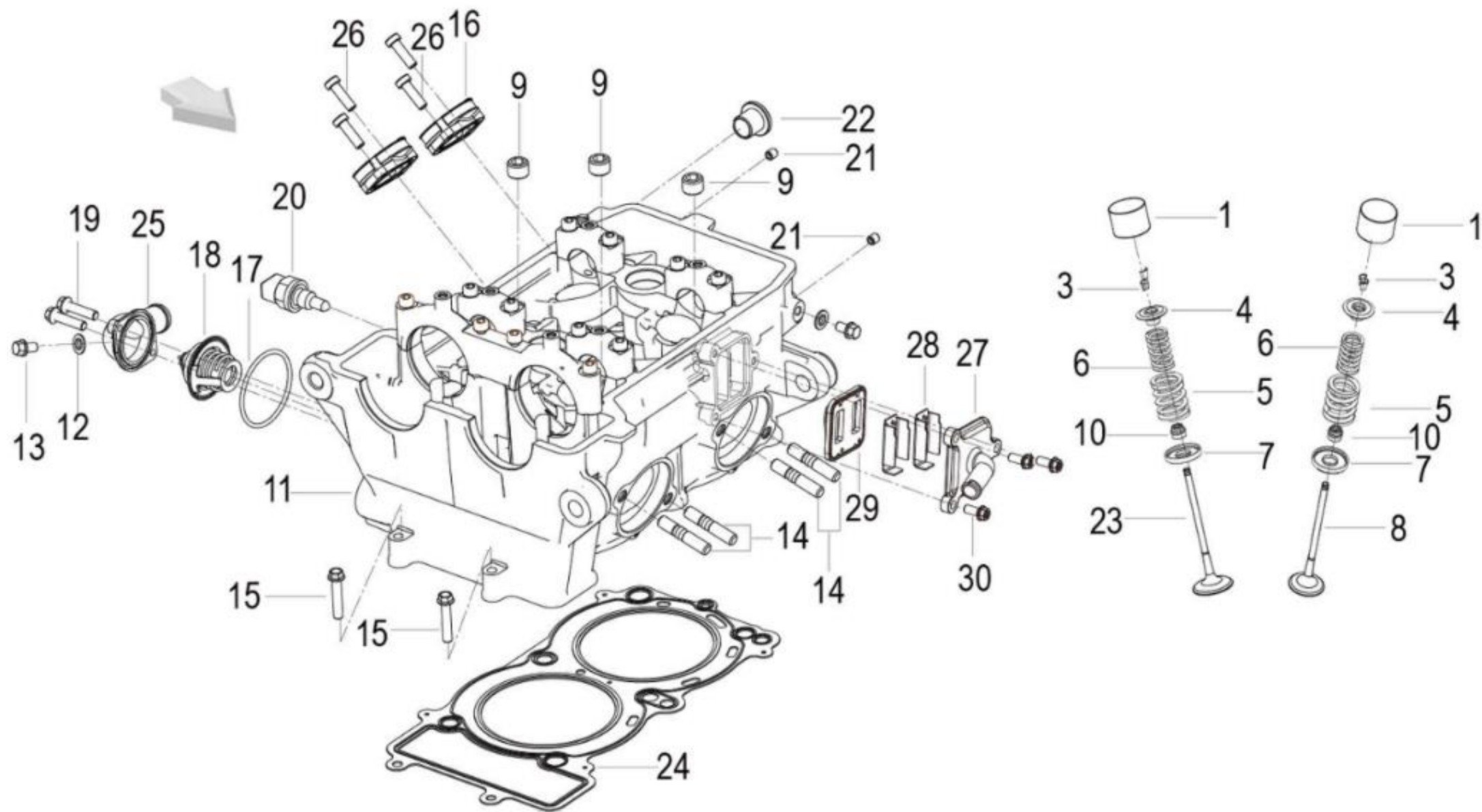

POSITION NO.	CODE	CN DESCRIPTION	EN DESCRIPTION	QTY / UNIT	REMARKS
E02-01	120156060011	气门挺柱δ5.5	TAPPET δ5.5	8	
E02-01	120156060012	气门挺柱δ5.525	TAPPET δ5.525	8	
E02-01	120156060013	气门挺柱δ5.55	TAPPET δ5.55	8	
E02-01	120156060014	气门挺柱δ5.575	TAPPET δ5.575	8	
E02-01	120156060015	气门挺柱δ5.6	TAPPET δ5.6	8	
E02-01	120156060016	气门挺柱δ5.625	TAPPET δ5.625	8	
E02-01	120156060017	气门挺柱δ5.65	TAPPET δ5.65	8	
E02-01	120156060018	气门挺柱δ5.675	TAPPET δ5.675	8	
E02-01	120156060019	气门挺柱δ5.7	TAPPET δ5.7	8	
E02-01	120156060020	气门挺柱δ5.725	TAPPET δ5.725	8	
E02-01	120156060021	气门挺柱δ5.75	TAPPET δ5.75	8	
E02-01	120156060022	气门挺柱δ5.775	TAPPET δ5.775	8	
E02-01	120156060023	气门挺柱δ5.8	TAPPET δ5.8	8	
E02-01	120156060024	气门挺柱δ5.825	TAPPET δ5.825	8	
E02-01	120156060025	气门挺柱δ5.85	TAPPET δ5.85	8	
E02-01	120156060026	气门挺柱δ5.875	TAPPET δ5.875	8	
E02-01	120156060027	气门挺柱δ5.9	TAPPET δ5.9	8	
E02-01	120156060028	气门挺柱δ5.925	TAPPET δ5.925	8	
E02-01	120156060029	气门挺柱δ5.95	TAPPET δ5.95	8	
E02-01	120156060030	气门挺柱δ5.975	TAPPET δ5.975	8	
E02-01	120156060031	气门挺柱δ6	TAPPET δ6	8	
E02-01	120156060032	气门挺柱δ6.025	TAPPET δ6.025	8	
E02-01	120156060033	气门挺柱δ6.05	TAPPET δ6.05	8	
E02-01	120156060034	气门挺柱δ6.075	TAPPET δ6.075	8	
E02-03	120066090000	气门锁块	SPLIT KEEPERS /VALVE COTTER	16	
E02-04	120056090000	气门弹簧上座	VALVE UPPER SPRING SEAT	8	
E02-05	129266090000	气门外弹簧	VALVE OUTER SPRING	8	
E02-06	129256090000	气门内弹簧	VALVE INNER SPRING	8	
E02-07	129216060000	气门弹簧下座	VALVE LOWER SPRING SEAT	8	
E02-08	129186090000	进气门(Φ33)	INTAKE VALVE	4	
E02-09	100066090100	锥形塞M14×1.5×10	TAPER PLUG M14×1.5×10	3	
E02-10	120046090000	气门油封	VALVE STEM SEAL	8	

POSITION NO.	CODE	CN DESCRIPTION	EN DESCRIPTION	QTY / UNIT	REMARKS
E02-11	10905606BG50	气缸盖组件(哑黑)	CYLINDER HEAD	1	
E02-11A	10905606BG2Z	气缸盖组件(哑黑)	CYLINDER HEAD ASSY	1	
E02-12	120133090002	垫片	WASHER	2	
E02-13	B0107060106H	螺栓M6×10	BOLT M6×10	2	
E02-14	10004609001X	短双头螺柱	SHORT STUD BOLTS	4	
E02-15	160306030070	螺栓M6×30-8.8-ZG	BOLT M6×30-8.8-ZG	2	
E02-16	119016060000	进气管组件	INLET AIR PIPE	2	
E02-17	100026060000	O形圈3193 48.89×2.62	O RING 48.89×2.62	1	
E02-18	270186090000	自动调温器	THERMOSTAT	1	
E02-19	160306030050	螺栓M6×25	BOLT M6×25	2	
E02-20	280596090000	水温传感器	WATER TEMPERATURE SENSOR	1	
E02-21	150056090100	锥形螺钉M6×6	TAPER PLUG M6×6	2	
E02-22	150046090000	轴套	COLLAR	1	
E02-23	129196090000	排气门(Φ29)	EXHAUST VALVE	1	
E02-24	109076060000	缸盖垫片	CYLINDER HEAD GASKET	1	
E02-25	10910606BG10	恒温器室(哑黑)	THERMOSTAT COVER	1	
E02-26	B0282060208H	螺钉M6×20	SCREW M6×20	4	
E02-27	10016606BG00	二次补气盖(哑黑)	SECONDARY AIR INTAKE VALVE COVER	1	
E02-28	110036030000	回火阻止器	BACKFIRE	2	
E02-29	110066030000	簧片阀分组件	LEAF VALVE	1	
E02-30	160306030180	六角内梅花螺栓M6×14	BOLT,TORX HEAD M6×14	1	

E03 CYLINDER ASSY(气缸体分总成)

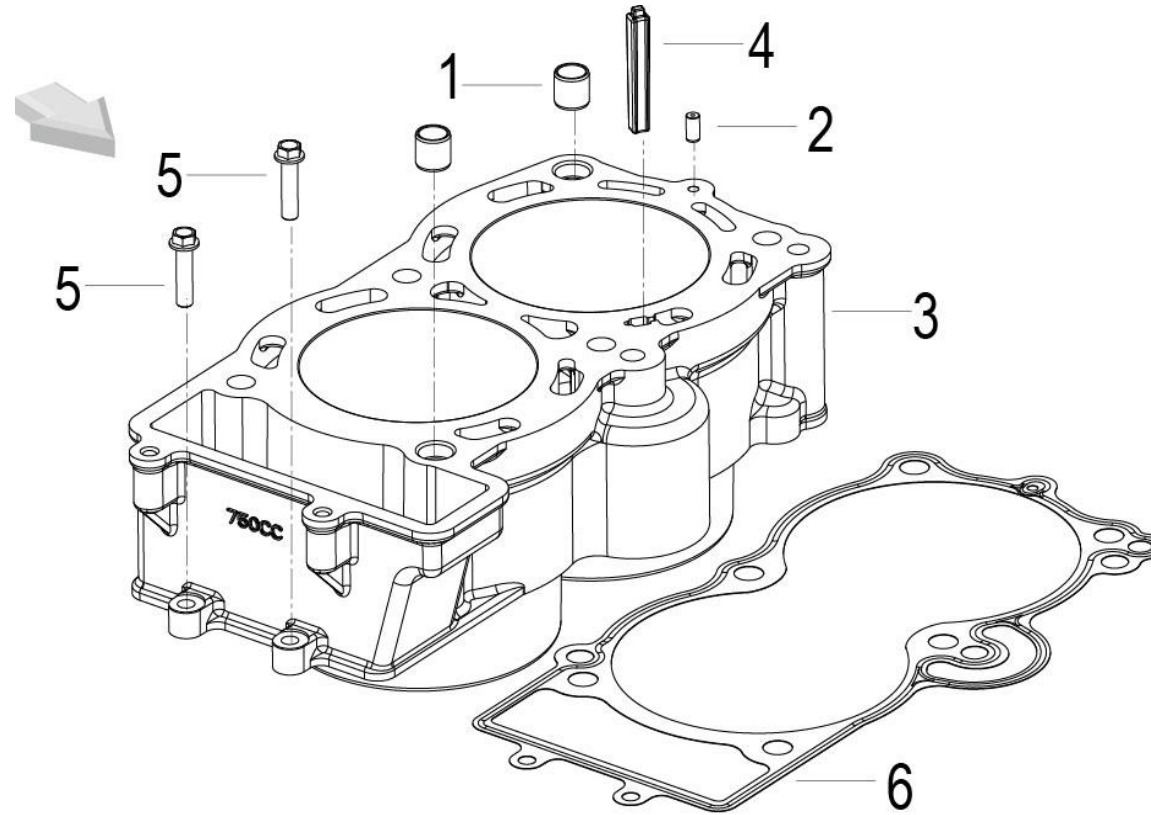

POSITION NO.	CODE	CN DESCRIPTION	EN DESCRIPTION	QTY / UNIT	REMARKS
E03-01	170236090000	定位销10.5×13×13	DOWEL PIN 10.5×13×13	2	
E03-02	150086060000	机油喷嘴	OIL JET	1	
E03-03	13903606BG30	气缸体(哑黑)	CYLINDER	1	
E03-04	130016060000	橡胶塞	RUBBER PLUG	1	
E03-05	160306030050	六角内梅花螺栓M6×25	BOLT M6×25	2	
E03-06	139026060000	气缸体垫片	GASKET,CYLINDER	1	



E04 VALVE MECHANISM SUB-ASSEMBLY(配气机构分总成)

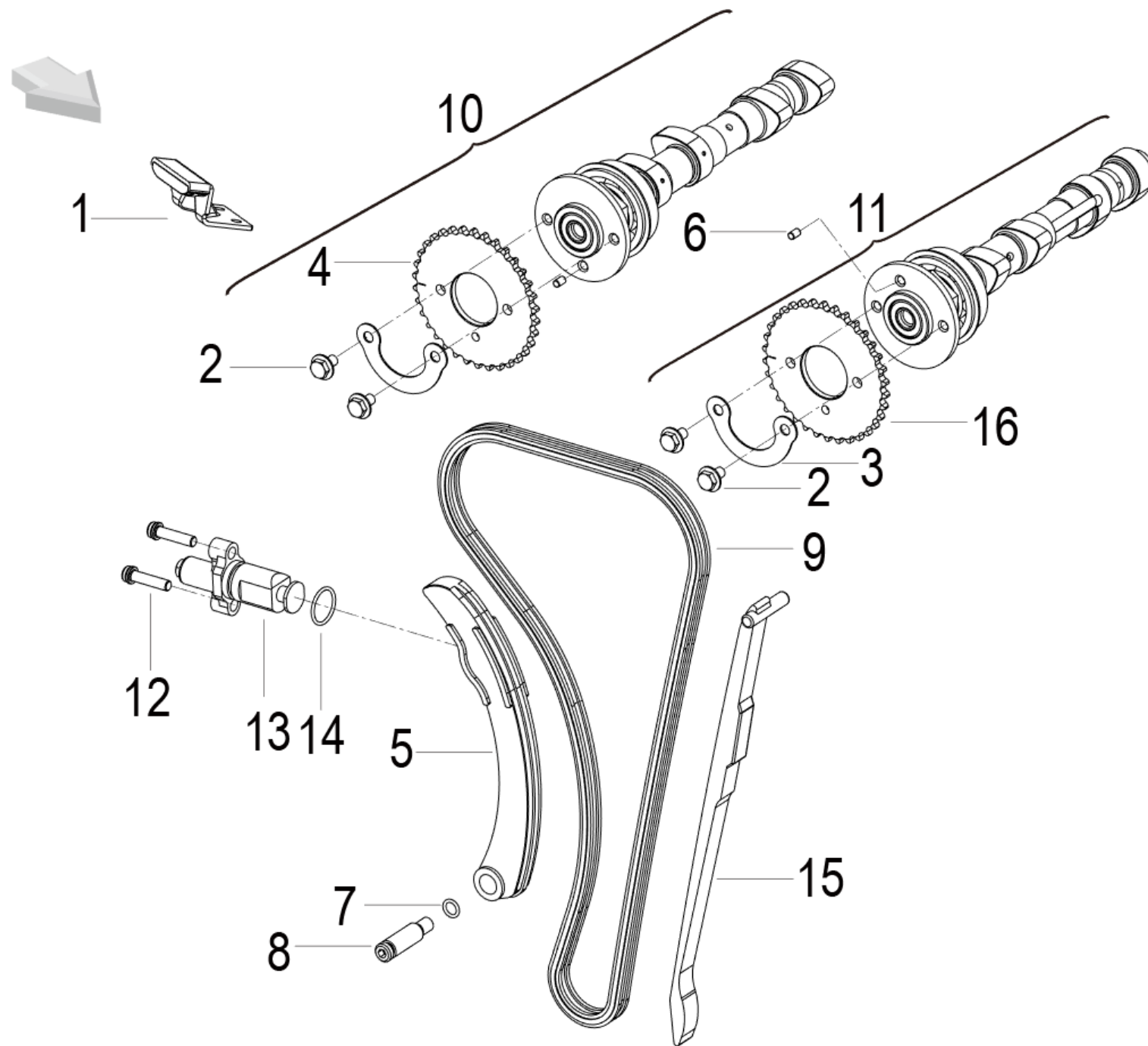

POSITION NO.	CODE	CN DESCRIPTION	EN DESCRIPTION	QTY / UNIT	REMARKS
E04-01	140086060000	上压块组件	TOP PRESSING BLOCK	1	
E04-02	120146090100	螺栓M6×11	BOLT M6×11	4	
E04-03	320016090010	定位垫片	WASHER	2	
E04-04	129286060000	进气凸轮轴从动链轮	SPROCKET,DRIVEN,INTAKE CAMSHAFT	1	
E04-05	149016060000	主导链板	MAIN GUIDE CHAIN PLATE	1	
E04-06	B091405008A0	定位销5×8	PIN,LOCATION 5×8	2	
E04-07	140036090000	O形圈2031 7.66×1.78	O-RING 2031 7.66×1.78	1	
E04-08	140026090000	主导链板销	PIN MAIN GUIDE CHAIN PLATE	1	
E04-09	129026060000	正时链条	CHAIN,TIMING	1	
E04-10	129116060010	进气凸轮轴组件(带链轮)	INTAKE CAMSHAFT ASSY	1	
E04-11	129126060010	排气凸轮轴组件(带链轮)	EXHAUST CAMSHAFT ASSY	1	
E04-12	150326090020	内梅花螺栓M6×25	BOLT M6×1×25	2	
E04-13	14903635BG00	张紧器组件(哑黑)	CAMSHAFT CHAIN TENSIONER	1	
E04-14	140106090000	O形圈2075 18.77×1.78	O-RING 2075 18.77×1.78	1	
E04-15	149026060000	副导链板组件	SECONDARY GUIDE CHAIN PLATE ASSY	1	
E04-16	129276060000	排气凸轮轴从动链轮	SPROCKET,DRIVEN,EXHAUST CAMSHAFT	1	

E05 PISTON,CONNECTING ROD & CRANKSHAFT ASSY(活塞连杆曲轴平衡轴分总成)

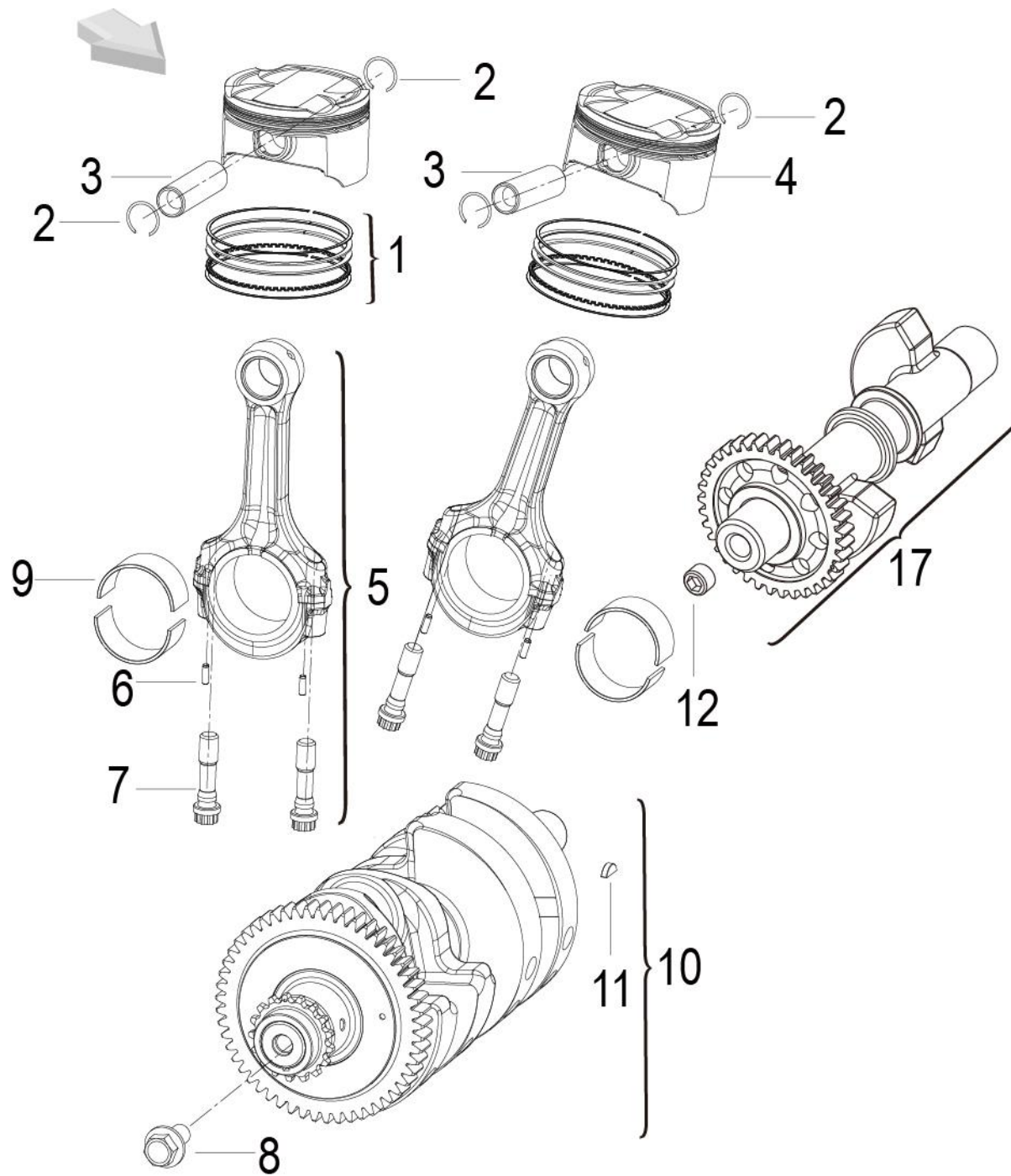

POSITION NO.	CODE	CN DESCRIPTION	EN DESCRIPTION	QTY / UNIT	REMARKS
E05-01	170336090020	活塞环组件	PISTON RING	2set	
E05-02	170216090000	活塞销卡环	CIRCLIP	2	
E05-03	179146350000	活塞销	PISTON PIN	2	
E05-04	179136350010	活塞	PISTON	2	
E05-05	179036090010	连杆组合	CONNECTING ROD ASSY	2	
E05-06	B091403010A0	圆柱销3×10	PIN 3×10	4	
E05-07	170196090000	连杆螺栓M9×1	CONNECTING ROD BOLT M9×1	4	
E05-08	B0109100166H	螺栓M10×16	BOLT M10×16	1	
E05-09	170206090010	连杆大头轴瓦(红)	CRANKSHAFT JOURNAL BEARING,RED	4	
E05-09	170206090030	连杆大头轴瓦(黄)	CRANKSHAFT JOURNAL BEARING,YELLOW	4	
E05-09	170206090020	连杆大头轴瓦(蓝)	CRANKSHAFT JOURNAL BEARING,BLUE	4	
E05-10	170016060030	曲轴组件	CRANKSHAFT ASSY	1	
E05-11	B11810305013	半圆键3×5×13	WOODRUFF KEY	1	
E05-12	100066090000	锥形塞M14×1.5×10	TAPER PLUG M14×1.5×10	1	
E05-17	179246060060	平衡轴分总成	BALANCE SHAFT ASSY	1	

E06 CRANKCASE ASSY(箱体分总成)

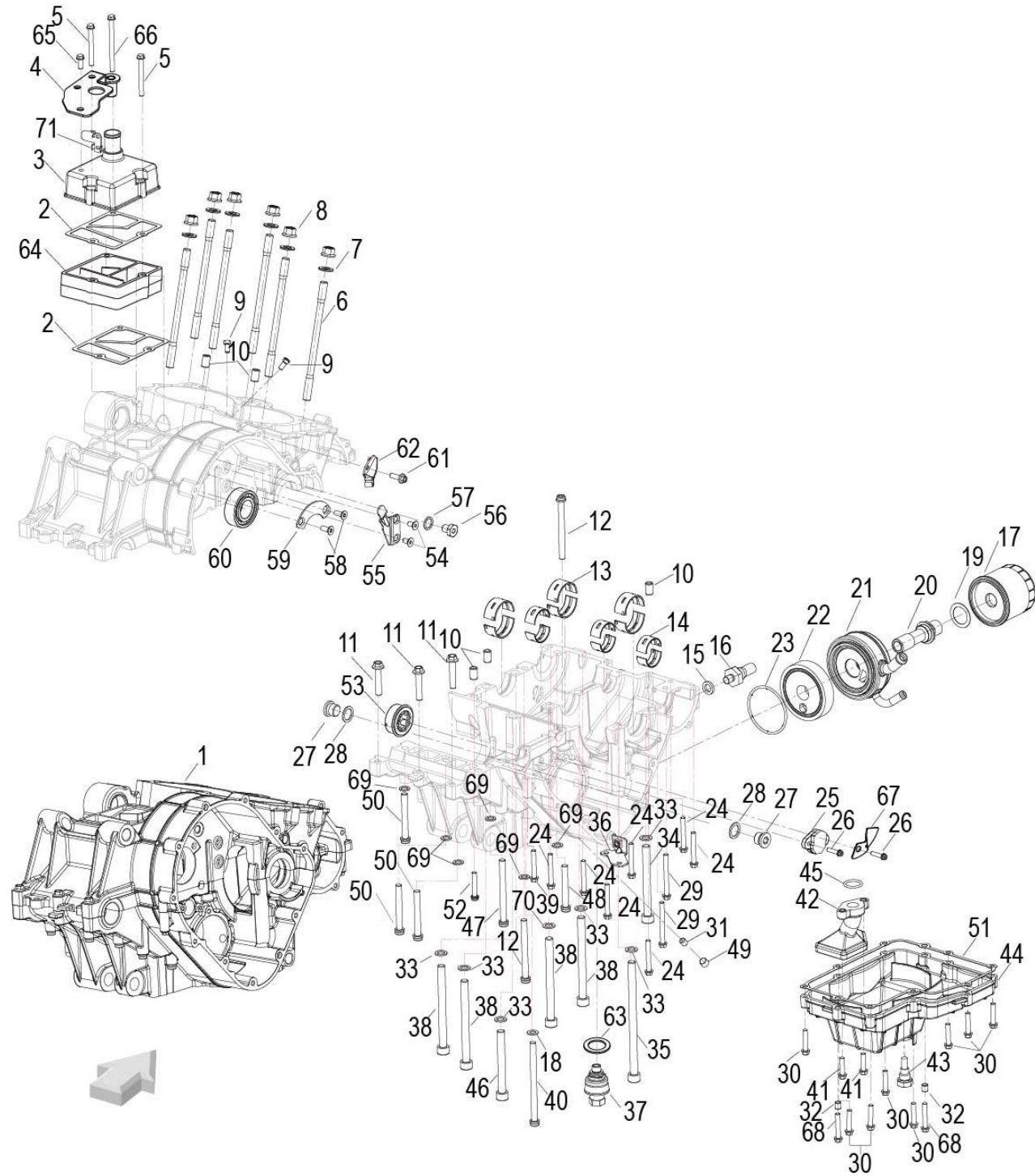



POSITION NO.	CODE	CN DESCRIPTION	EN DESCRIPTION	QTY / UNIT	REMARKS
E06-01	15034606BG20	箱体组合(哑黑)	CRANKCASE ASSY	1	
E06-02	200106060010	呼吸阀盖垫片	BREATHER VALVE GASKET	2	
E06-03	15001606BG00	呼吸阀盖(哑黑)	BREATHER VALVE COVER	1	
E06-04	58670P290001	ABS安装板支撑座焊接组件	ABS MOUNTING PLATE	1	
E06-05	B0107060656H	螺栓M6×65	BOLT M6×65	2	
E06-06	150336060000	双头螺栓	STUD BOLT	6	
E06-07	120096090000	垫片10.5×19.8×2	WASHER 10.5×19.8×2	6	
E06-08	120106090010	法兰面螺母M10×1	NUT M10×1	6	
E06-09	150146060000	堵头	PLUG	2	
E06-10	150016090000	定位销6×10×16	DOWEL PIN 6×10×16	5	
E06-11	B0182080406H	螺栓M8×40-8.8-ZG	BOLT M8×40	3	
E06-12	B02050808564	螺钉M8×85	SCREW M8×85	2	
E06-13	150356060010	曲轴轴瓦(红色)	CRANKCASE BEARING SHELL,RED	6	
E06-13	150356060020	曲轴轴瓦(蓝色)	CRANKCASE BEARING SHELL,BLUE	6	
E06-13	150356060030	曲轴轴瓦(黄色)	CRANKCASE BEARING SHELL,YELLOW	6	
E06-14	159066060010	平衡轴轴瓦(绿色)	BALANCE BEARING SHELL,GREEN	6	
E06-14	159066060020	平衡轴轴瓦(黑色)	BALANCE BEARING SHELL,BLACK	6	
E06-14	159066060030	平衡轴轴瓦(茶色)	BALANCE BEARING SHELL,BROWN	6	
E06-14	159066060040	平衡轴轴瓦(黄色)	BALANCE BEARING SHELL,YELLOW	6	
E06-15	240056090000	垫片 11×18×3	WASHER B0417060004H	1	
E06-16	240026090000	最小机油压力开关	MINIMUM OIL PRESSURE SWITCH	1	
E06-17	260146090011	机油滤清器	OIL FILTER	1	
E06-18	150225040000	垫圈	WASHER	1	
E06-19	B07840002500	垫片25×35×0.5	WASHER 25×35×0.5	1	
E06-20	260016240001	油冷器固定螺栓	BOLT	1	
E06-21	260026060002	油冷器组件	COLD OIL ASSEMBLY	1	
E06-22	260046240000	油冷器接头	OIL COOLER TIE-IN	1	
E06-23	270056030000	O型圈	O-RING	1	
E06-24	B0107060456H	螺钉M6×45	SCREW M6×45	7	
E06-25	210066060000	挡位传感器	GEAR SENSOR	1	
E06-26	B0205050206H	螺钉M5×20	SCREW M5×20	2	

POSITION NO.	CODE	CN DESCRIPTION	EN DESCRIPTION	QTY / UNIT	REMARKS
E06-27	150186090000	圆柱形塞	CYLINDER STOPPER	2	
E06-28	150176090000	垫片16×22×1.5	WASHER 16×22×1.5	2	
E06-29	150316030200	螺栓M6×60	BOLT M6×60	2	
E06-30	160106030130	螺栓M6×30-8.8-ZG	BOLT M6×30	10	
E06-31	150196090000	机油分配螺塞	PLUG	1	
E06-32	150156090000	定位销6.4×8×9	DOWEL PIN 6.4×8×9	2	
E06-33	150036090000	垫片10.5×16.5×1.5	WASHER 10.5×16.5×1.5	6	
E06-34	B02551010298	螺钉M10×1.25×102	SCREW M10×1.25×102	1	
E06-35	B02551016598	螺钉M10×1.25×165	SCREW M10×1.25×165	1	
E06-36	59530P290000	水箱支撑座安装座	WATER TANK SUPPORT SEAT	1	
E06-37	159226350000	溢流阀组件	OVER FLOW VALVE	1	
E06-38	B02551011998	螺钉M10×1.25×119	SCREW M10×1.25×119	4	
E06-39	150316030150	螺栓M6×40	BOLT M6×40	1	
E06-40	B0205081158H	螺钉M8×115	SCREW M8×115	1	
E06-41	160106030120	螺栓M6×25	BOLT M6×25	2	
E06-42	260086060000	吸入机油过滤器	SUCTION ENGINE OIL FILTER	1	
E06-43	260346030010	磁性螺栓组件M14×1	MAGNETISM BOLT M14×1	1	
E06-44	10901606BG00	油底壳(哑黑)	SUMP COVER	1	
E06-45	170036090000	O形圈128 20.63×2.62	O-RING 128 20.63×2.62	1	
E06-46	B02551009098	螺钉M10×1.25×90	SCREW M10×1.25×90	1	
E06-47	B0205080906H	螺钉M8×90	SCREW M8×90	1	
E06-48	B0205080606H	螺钉M8×60	SCREW M8×60	1	
E06-49	150166090010	锥形塞M10×1	TAPER PLUG M10×1	1	
E06-50	B0205080656H	螺钉M8×65	SCREW M8×65	3	
E06-51	200086060000	油底壳纸垫	SUMP COVER GASKET	1	
E06-52	B0281060356H	螺钉M6×35	SCREW M6×35	1	
E06-53	150126090000	滚针轴承18×40×17	NEEDLE BEARING 18×40×17	1	
E06-54	B0285060126H	螺钉M6×12-8.8-ZG	SCREW M6×12-8.8-ZG	2	
E06-55	150056060000	压线板	BINDER PLATE	1	
E06-56	210076060100	螺栓M10×1×12	BOLT M10×1×12	1	
E06-57	100056060000	垫片13.5×18×1.5	WASHER 13.5×18×1.5	1	
E06-58	B0217060168H	螺钉M6×1×16	SCREW M6×1×16	2	

POSITION NO.	CODE	CN DESCRIPTION	EN DESCRIPTION	QTY / UNIT	REMARKS
E06-59	210046060000	主轴轴承限位板	BEARING PRESSURE BOARD	1	
E06-60	150386060000	双列滚子轴承25×52×18	ROLLING BEARING	1	
E06-61	B0107060146H	螺栓M6×14	BOLT M6×14	1	
E06-62	200306060001	离合器拉线支架	BRACKET,CLUTCH CABLE	1	
E06-63	260126090000	垫片12.5×18×1.5	WASHER 12.5×18×1.5	1	
E06-64	15017606BG00	迷宫(哑黑)	MAZE	1	
E06-65	B0107060126H	六角头法兰面螺栓M6×12	BOLT M6×12	1	
E06-66	B0109060856H	螺栓M6×85	BOLT M6×85	1	
E06-67	150136060000	挡位线压板	PRESSURE BOARD	1	
E06-68	270016220110	螺栓M6×35	BOLT M6×35	2	
E06-69	B0703000080H	垫圈8	WASHER 8	6	
E06-70	159346190000	铜垫片	COPPER GASKET	1	
E06-71	58680P370000	闪光器安装板组件	BRACKET	1	

E07 GEAR SHIFT MECHANISM ASSEMBLY (变速换挡机构分总成)

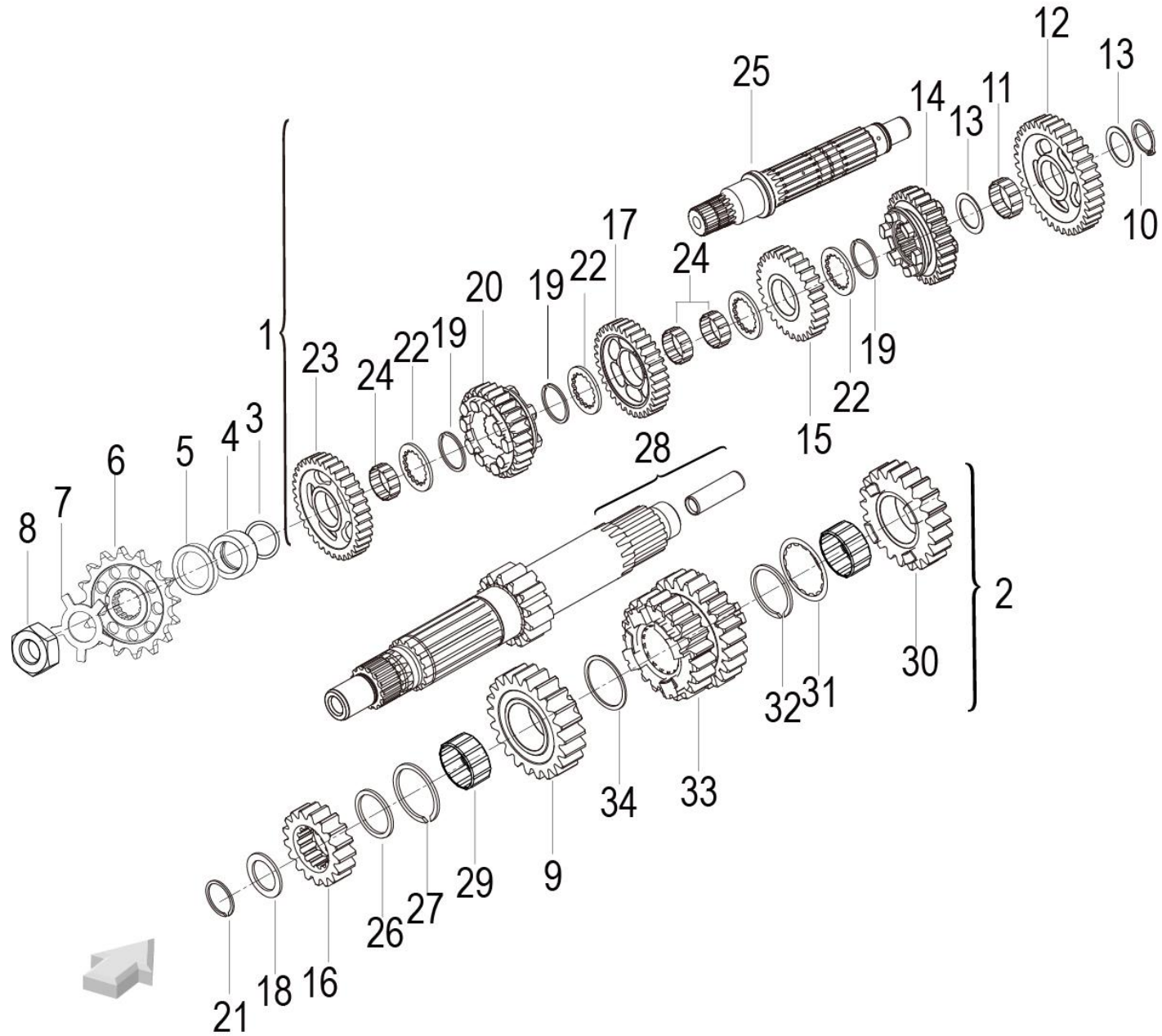

POSITION NO.	CODE	CN DESCRIPTION	EN DESCRIPTION	QTY / UNIT	REMARKS
E07-01	219216060010	副轴组件	SECONDARY SHAFT	1	
E07-02	219136060010	主轴组件	PRIMARY SHAFT	1	

POSITION NO.	CODE	CN DESCRIPTION	EN DESCRIPTION	QTY / UNIT	REMARKS
E07-03	210316030000	O形密封圈	O RING	1	
E07-04	210186060000	输出链轮隔套	COLLAR	1	
E07-05	B2204FB47357	油封35×47×7	OIL SEAL 35×47×7	1	
E07-06	210186090000	输出链轮Z16	DRIVE SPROCKET Z16	1	
E07-07	210196090000	防松垫片	ANTI LOOSEN WASHER	1	
E07-08	210196030000	螺母M18×1.0	NUT M18×1.0	1	
E07-09	219206060010	主轴六档齿轮	PRINCIPALSHAFT GEAR 6	1	
E07-10	B080100025A0	轴用弹性挡圈φ25×2	ELASTIC CIRCLIP φ25×2	1	
E07-11	210056090000	滚针轴承K25×29×10	NEEDLE BEARING K25×29×10	1	
E07-12	219236060010	副轴一档齿轮	COUNTERSHAFT GEAR 1 ASSY	1	
E07-13	210066090000	垫圈	WASHER	2	
E07-14	219276060010	副轴五档齿轮	COUNTERSHAFT GEAR 5	1	
E07-15	219266060010	副轴四档齿轮	COUNTERSHAFT GEAR 4	1	
E07-16	219166060010	主轴二档齿轮	PRINCIPALSHAFT GEAR 2	1	
E07-17	219256060010	副轴三档齿轮	COUNTERSHAFT GEAR 3	1	
E07-18	210046090000	垫片18×26×1.5	WASHER 18×26×1.5	1	
E07-19	210086090000	弹性卡圈(弹性环)	ELASTIC RING 30×1.5	3	
E07-20	219286060010	副轴六档齿轮	COUNTERSHAFT GEAR 6	1	
E07-21	210036090000	弹性环18×1.2	ELASTIC RING 18×1.2	1	
E07-22	219446060000	花键垫片	SPLINE WASHER	3	
E07-23	219246060010	副轴二档齿轮	COUNTERSHAFT GEAR 2	1	
E07-24	219406060000	滚针轴承KS26×30×13TN	NEEDLE BEARING KS26×30×13TN	3	
E07-25	219226060010	副轴	COUNTERSHAFT	1	
E07-26	210106060000	弹性环24	ELASTIC RING 24	1	
E07-27	219436060000	垫圈25×35×3.5	WASHER 25×35×3.5	1	
E07-28	219146060010	主轴	PRIMARY SHAFT	1	
E07-29	219396060000	滚针轴承24×28×13	NEEDLE BEARING 24×28×13	2	
E07-30	219196060010	主轴五档齿轮	PRINCIPALSHAFT GEAR 5	1	
E07-31	219416060000	花键垫圈	WASHER 28.5×33×1	1	
E07-32	210246030000	弹性卡圈28(档圈28)	SPRING RING 28	1	
E07-33	210376060010	主轴三四档齿轮	PRINCIPALSHAFT GEAR 3,4	1	
E07-34	219426060000	垫圈25×32×2	WASHER 25×32×2	1	



E08 GEAR SHIFT MECHANISM ASSEMBLY (变速换挡机构分总成)

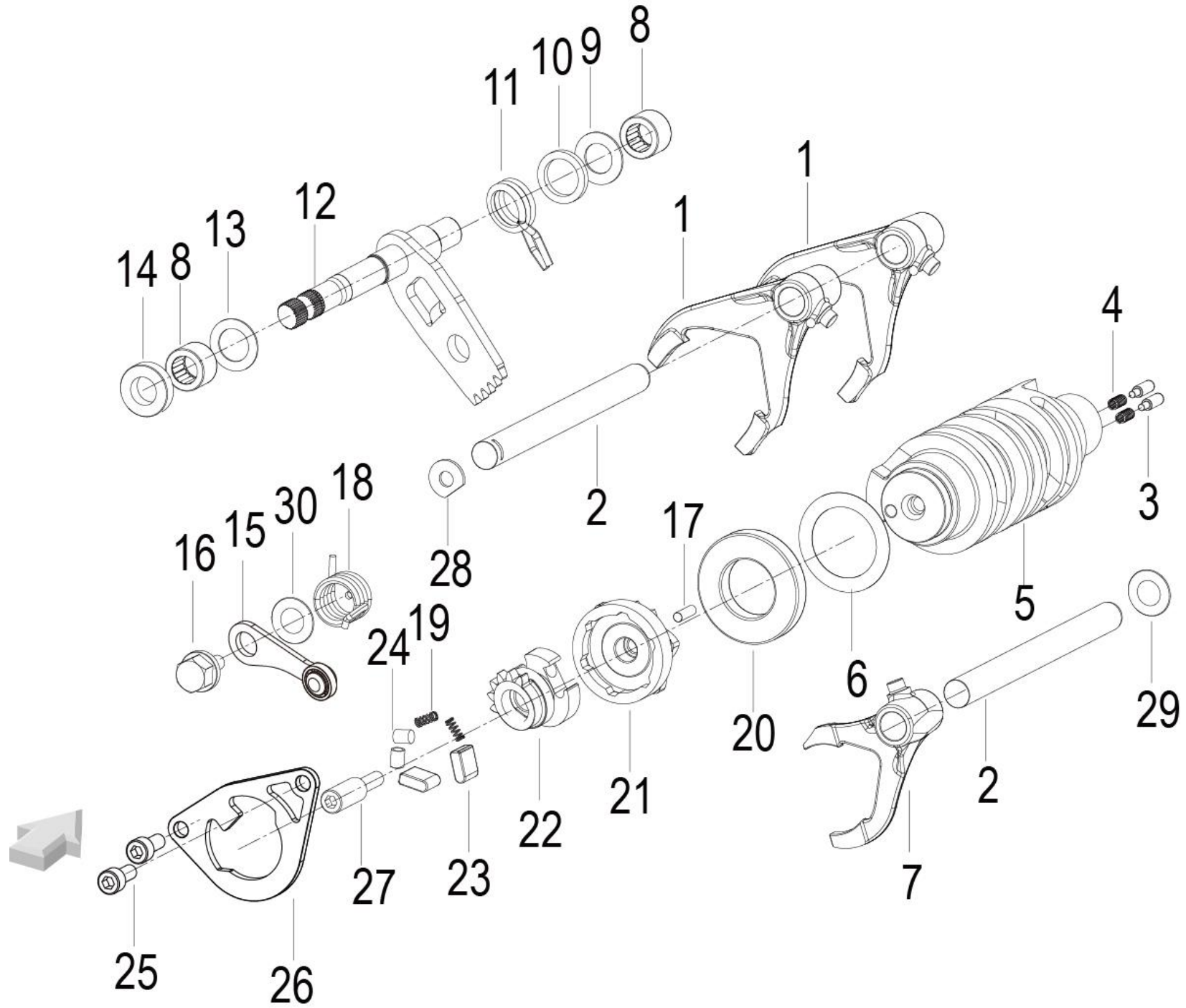

POSITION NO.	CODE	CN DESCRIPTION	EN DESCRIPTION	QTY / UNIT	REMARKS
E08-01	210356060000	副轴拨叉	SHIFT FORK,SECONDARY SHAFT	2	
E08-02	219086060000	拨叉轴	SHIFT FORK SHAFT	2	
E08-03	210036060000	挡位销	PIN	2	
E08-04	270066060000	档位销弹簧	SPRING	2	
E08-05	219056060020	变挡鼓	SHIFT DRUM	1	
E08-06	210276090000	垫片25×30×SP	WASHER 25×30×SP	1	
E08-07	219106060000	主轴拨叉	SHIFT FORK,PRIMARY SHAFT	1	
E08-08	B1212K121202	滚针轴承HK1212B 12×18×12	NEEDLE BEARING HK1212B 12×18×12	2	
E08-09	210426090000	垫片12.8×22×1	WASHER 12.8×22×1	1	
E08-10	320106090000	垫片16×22×3	WASHER 16×22×3	1	
E08-11	210436090000	回位弹簧	RETURN SPRING	1	
E08-12	210256060010	变档杆组件	SHIFT SHAFT	1	
E08-13	320116090000	垫片14×22×0.8	WASHER 14×22×0.8	1	
E08-14	210496090000	油封12×22×6/6.5	OIL SEAL 12×22×6/6.5	1	
E08-15	210226060010	变档定位滚轮组合	SHIFT POSITIONING ROLLER ARM ASSEMBLY	1	
E08-16	210356090000	变档定位滚轮臂轴	SHIFT POSITIONING ROLLER ARM AXLE	1	
E08-17	210266090000	圆柱销4×12.8	PIN 4×12.8	1	
E08-18	270076060000	防脱挡弹簧	SPRING	1	
E08-19	210475150000	棘爪弹簧	RATCHET SPRING	2	
E08-20	B12011600501	轴承16005 25×47×8	BEARING 25×47×8	1	
E08-21	210216060000	星型定位板	GEAR SELECTOR DRUM	1	
E08-22	210466060010	分离座	BLOCK SEPARATION	1	
E08-23	210316090000	分离块	SEPARATION PIECE	2	
E08-24	210326090000	分离块销	SEPARATION PIECE PIN	2	
E08-25	210556090000	螺栓M6×14	BOLT M6×14	2	
E08-26	210246060010	定位板	FIXED POSITION PLANK	1	
E08-27	210296090000	星形定位板固定销	FIX PIN	1	
E08-28	210366060000	垫片	WASHER	1	
E08-29	150066090000	垫片6.5×16×1.5	WASHER 6.5×16×1.5	1	
E08-30	219494320000	垫片6.3×16×1	WASHER 6.3×16×1	1	

E09 GEAR COVER (齿轮室盖)

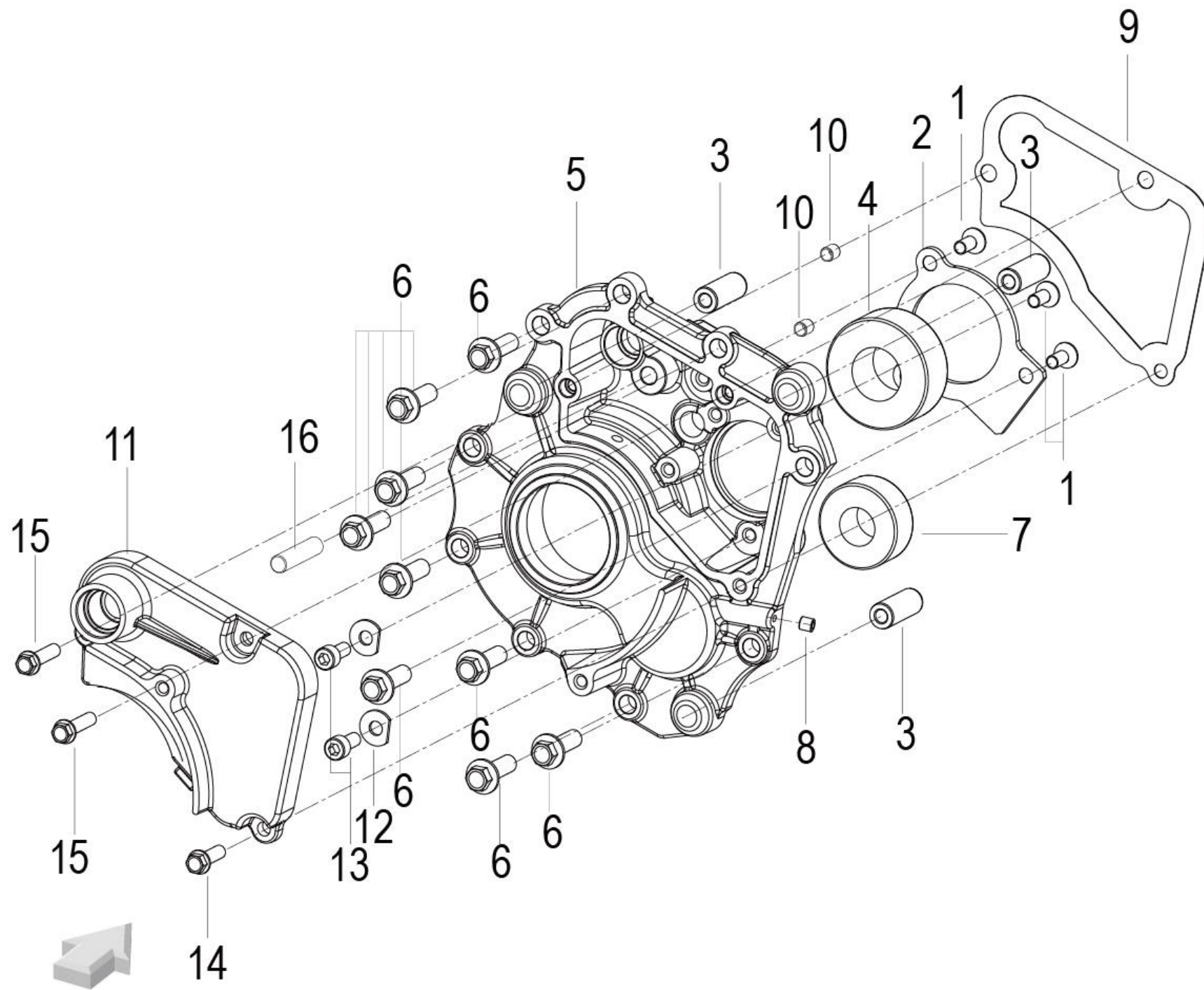

POSITION NO.	CODE	CN DESCRIPTION	EN DESCRIPTION	QTY / UNIT	REMARKS
E09-01	B02170601469	螺钉M6×1×14	SCREW M6×1×14	3	
E09-02	210206060000	轴承固定板	BEARING LIMIT BOARD	1	
E09-03	150206090000	定位销6×12×30	DOWEL PIN 6×12×30	3	
E09-04	B12150320501	滚动轴承3205A	BEARING 3205A	1	
E09-05	22001606BG00	齿轮室盖(哑黑BG)	GEAR BOX COVER	1	
E09-06	B0107080256H	螺栓M8×25	BOLT M8×25	9	
E09-07	210166090000	滚针轴承18×40×17	NEEDLE BEARING 18×40×17	1	
E09-08	43255S010010	内六角平端紧定螺钉M4×6	SCREW M4×6	1	
E09-09	210266060000	变档盖垫片	GASKET	1	
E09-10	150156090000	定位销6.4×8×9	DOWEL PIN 6.4×8×9	2	
E09-11	25007608BG00	变档盖(哑黑BG)	SHIFT COVER	1	
E09-12	210366060000	垫片	WASHER	2	
E09-13	210556090000	螺栓M6×14	BOLT M6×14	2	
E09-14	160306030030	螺栓M6×20	BOLT M6×20	1	
E09-15	160306030050	螺栓M6×25	BOLT M6×25	2	
E09-16	210246090000	定位销8×36	DOWEN PIN 8×36	1	

E10 ELECTRIC STARTER ASSY(电启动分总成)

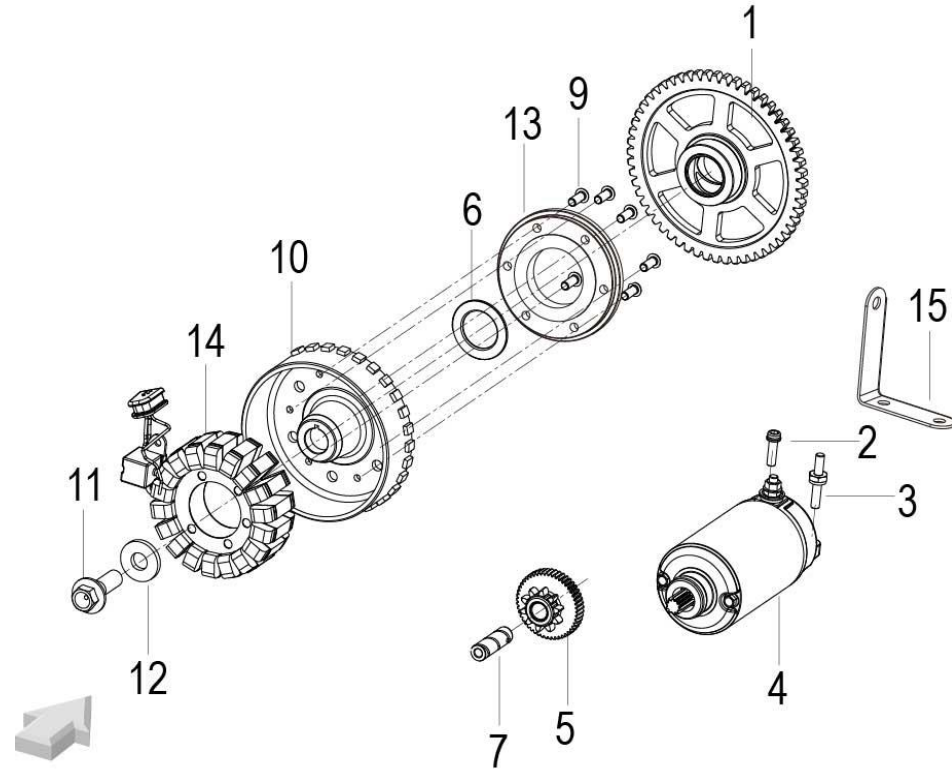

POSITION NO.	CODE	CN DESCRIPTION	EN DESCRIPTION	QTY / UNIT	REMARKS
E10-01	249106060000	超越离合器齿轮Z56组合	STARTER MOTOR CLUTCH GEAR	1	
E10-02	160306030030	六角内梅花螺栓M6×20	BOLT,TORX HEAD M6×20	1	
E10-03	08001P300000	双头螺栓M6-M6	STUD BOLT M6-M6	1	
E10-04	249016060000	启动电机	STARTER MOTOR	1	
E10-05	249046060000	双联齿轮组件	STARTER MOTOR GEAR	1	
E10-06	240066060000	间隙环	CLEARANCE RING	1	
E10-07	240046060000	过渡齿轮轴	STARTER MOTOR GEAR SHAFT	1	
E10-09	B0218060156H	内六角平圆头螺钉M6×15	SCREW M6×15	6	
E10-10	299026060010	飞轮组合	GENERATOR ROTOR	1	
E10-11	240106060000	螺栓M12×1.5×38	SCREW M12×1.5×38	1	
E10-12	170106030020	垫片13×30×4	WASHER 13×30×4	1	
E10-13	249096060010	超越离合器组件	STARTER MOTOR CLUTCH	1	
E10-14	299036060010	定子组件	STATOR COIL	1	
E10-15	280636060000	启动电机线夹	STARTER MOTOR CLIP	1	



E11 CLUTCH SYSTEM(离合器分总成)

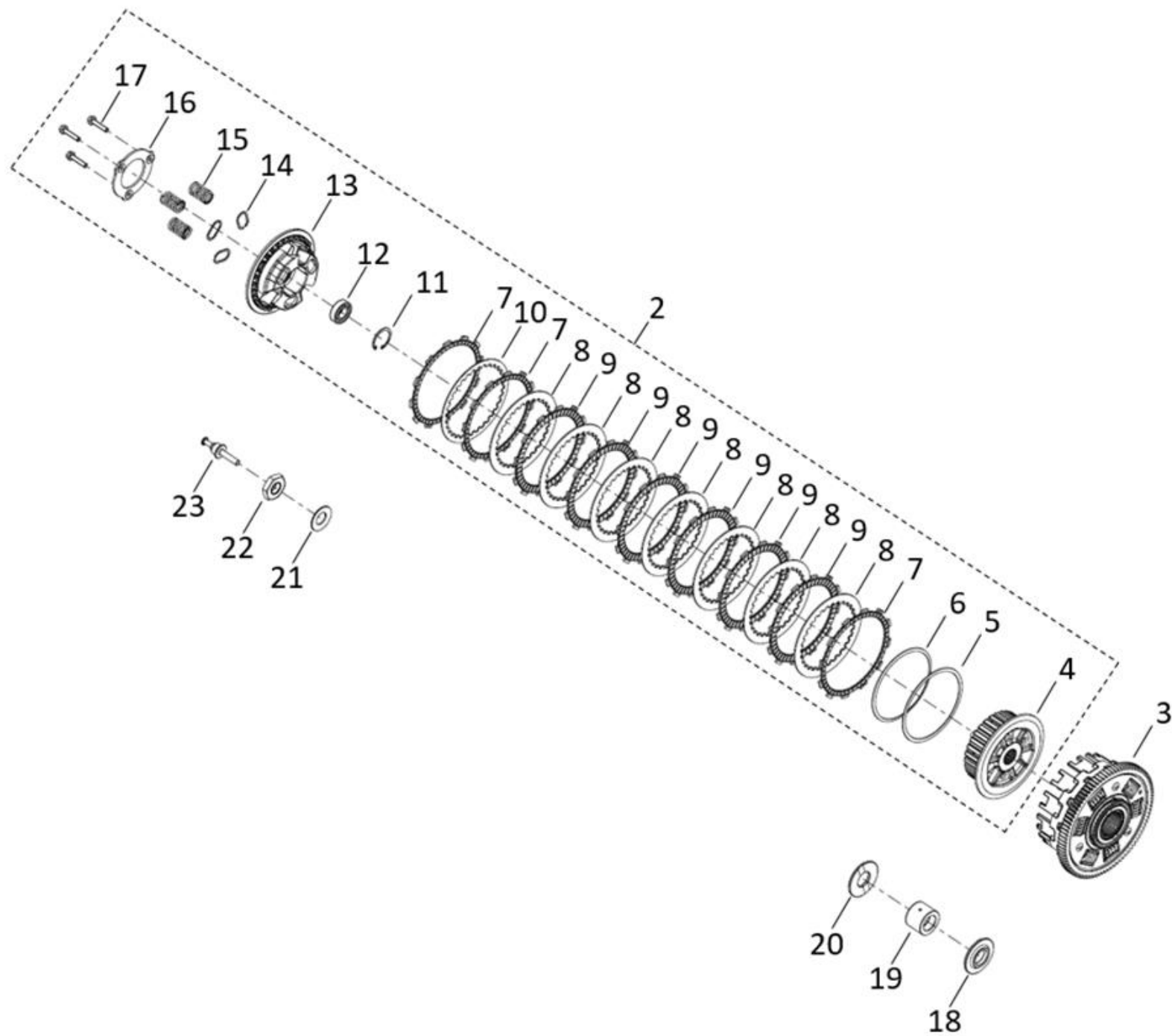

POSITION NO.	CODE	CN DESCRIPTION	EN DESCRIPTION	QTY / UNIT	REMARKS
E11-02	209036060050	离合器从动盘组件	CLUTCH CENTER COMP	1	
E11-03	200126060050	离合器主动毂组件	CLUTCH OUTER COMP	1	
E11-04	209146060040	离合器从动毂/滑块状态	CLUTCH CENTER	1	
E11-05	209236060020	垫圈	WASHER	1	
E11-06	209226060010	蝶形弹簧	SPRING	1	
E11-07	209196060050	离合器摩擦片II	FRICTION PLATE II	3	
E11-08	209246060010	离合器片(2)	CLUTCH PLATE(2)	7	
E11-09	200246060050	离合器摩擦片	FRICTION PLATE	6	
E11-10	209176060010	离合器片IV	CLUTCH PLATE IV	1	
E11-11	B080000035A0	孔用挡圈φ35	CIRCLIP 35	1	
E11-12	B12016000303	滚动轴承	BEARING	1	
E11-13	209216060040	离合器压盘	PRESSURE PLATE	1	
E11-14	200326060040	弹簧垫片	WASHER	3	
E11-15	209256060010	离合器弹簧	CLUTCH SPRING	3	
E11-16	209206060010	弹簧压板	SPRING PLATE	1	
E11-17	209276060000	螺栓M6×30	BOLT M6×30	3	
E11-18	200146060000	内部间隙环	INTERNAL CLEARANCE RING	1	
E11-19	200166060000	离合器轴套	CLUTCH COLLAR	1	
E11-20	200156060000	外部间隙环	OUTER CLEARANCE RING	1	
E11-21	200046090000	蝶形弹簧	SPRING	1	
E11-22	200296090010	螺母M20×1	NUT M20×1	1	
E11-23	209066060020	离合器拉杆	CLUTCH LEVER	1	

E12 LEFT COVER ASSY (左盖分总成)

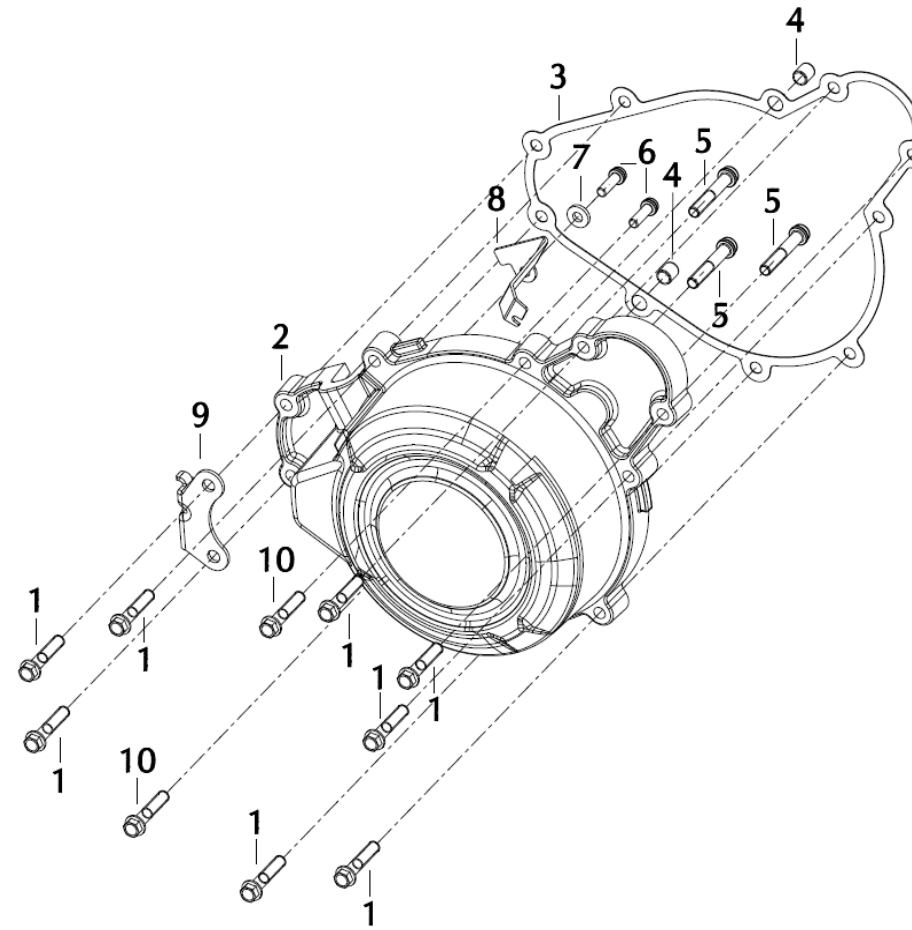

POSITION NO.	CODE	CN DESCRIPTION	EN DESCRIPTION	QTY / UNIT	REMARKS
E12-01	160306030070	六角内梅花螺栓M6×30	BOLT M6×30	8	
E12-02	27002606BG20	左盖(哑黑)	LEFT COVER,GREY	1	
E12-03	169076060000	左盖垫片	LEFT COVER GASKET	1	
E12-04	150156090000	定位销	DOWEL PIN	2	
E12-05	160316030040	内梅花螺栓M6×35	SCREW M6×35	3	
E12-06	B02810501662	螺栓M5×0.8×16	BOLT M5×0.8×16	2	
E12-07	160036060000	垫片5.5×12×2	WASHER 5.5×12×2	1	
E12-08	200116060010	出线压板	PRESS PLATE	1	
E12-09	58650P380000	底罩左安装座	MOUNTING BASE OF BOTTOM COVER,LEFT	1	
E12-10	160306030080	六角内梅花螺栓M6×35	BOLT M6×35	2	

E13 RIGHT COVER ASSY (右盖分总成)

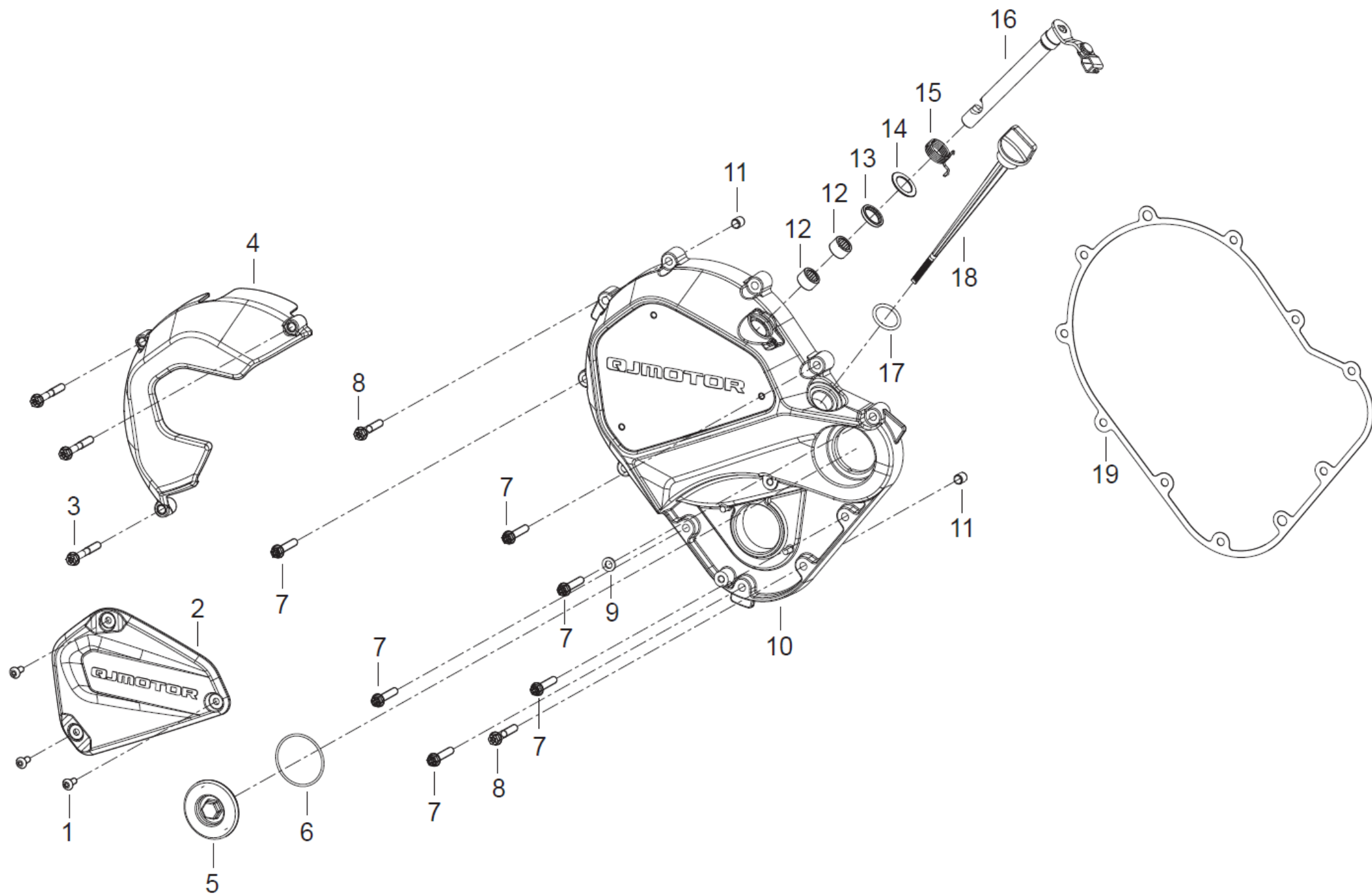

POSITION NO.	CODE	CN DESCRIPTION	EN DESCRIPTION	QTY / UNIT	REMARKS
E13-01	B02180501262	螺钉M5×12	SCREW M5×12	3	
E13-02	169146060000	右小盖	RIGHT SMALL COVER	1	
E13-03	160306030100	六角内梅花螺栓M6×45	BOLT M6×45	3	
E13-04	169206060020	右盖护罩组件	RIGHT COVER SHIELD	1	
E13-05	16004606BG00	相位塞(哑黑)	PHASE PLUG	1	
E13-06	160056090000	O形圈2162 41×1.78	O -RING 41×1.78	1	
E13-07	160306030070	六角内梅花螺栓M6×30	BOLT M6×30	6	
E13-08	160306030080	六角内梅花螺栓M6×35	BOLT M6×35	2	
E13-09	160131170000	垫圈6	WASHER 6	1	
E13-10	16902606BG60	右盖(哑黑)	RIGHT COVER	1	
E13-11	150156090000	定位销	DOWEL PIN	2	
E13-12	B1212K121002	滚针轴承12×16×10	NEEDLE BEARING 12×16×10	2	
E13-13	200326090000	油封15×21×3	OIL SEAL 15×21×3	1	
E13-14	160026060000	垫片15×25×1	WASHER 15×25×1	1	
E13-15	200096060000	回位弹簧	SPRING	1	
E13-16	209046060030	离合器控制拉杆组合	CLUTCH CONTROL LEVER	1	
E13-17	160063070000	O型圈18×3.5	O -RING 18×3.5	1	
E13-18	169186060020	油尺	DIPSTICK	1	
E13-19	169116060000	右盖垫片	RIGHT COVER GASKET	1	



E14 COOLING SYSTEM (冷却系统分总成)

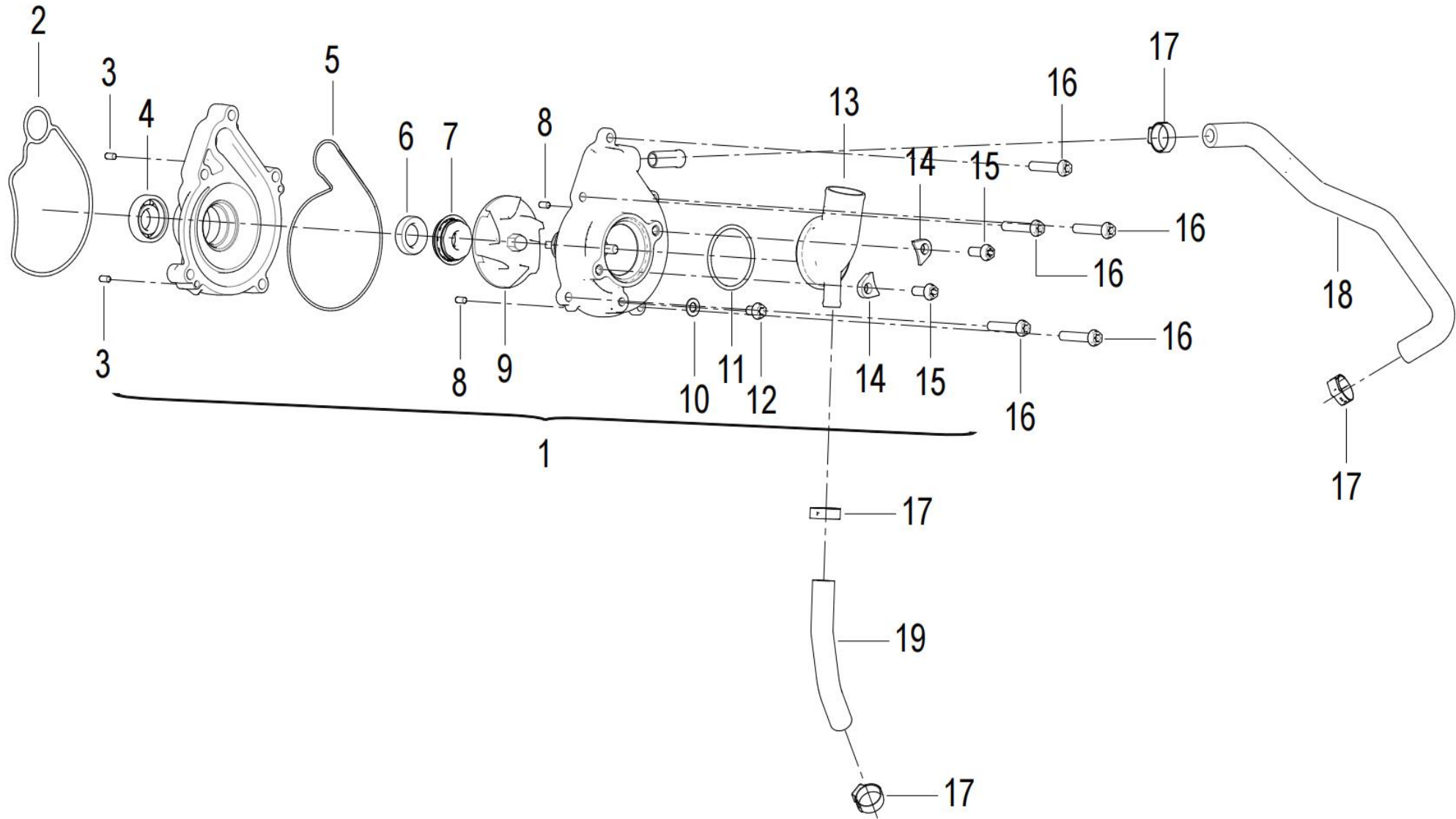

POSITION NO.	CODE	CN DESCRIPTION	EN DESCRIPTION	QTY / UNIT	REMARKS
E14-01	27925606BG50	水泵组件(哑黑)	WATER PUMP ASSEMBLY	1	
E14-02	279576060050	水泵体密封圈	WATER PUMP SEAL	1	
E14-03	B091404008B4	圆柱销4×8	PIN Φ4×8	2	
E14-04	B12011600201	轴承16002-C3 15×32×8	BEARING 16002-C315×32×8	2	
E14-05	270046060000	水泵密封圈	WATER PUMP SEAL	1	
E14-06	B22010B15267	油封15×26×7	OIL SEAL 15×26×7	1	
E14-07	279606060000	水封EKK	OIL SEAL ASSY	1	
E14-08	B091404008B4	圆柱销4×8	PIN Φ4×8	2	
E14-09	279216060050	水泵叶轮	WATER PUMP IMPELLER	1	
E14-10	170226090000	垫片6.5×12×1	WASHER 6.5×12×1	1	
E14-11	270096090000	O型环3156 39.34×2.62	O -RING 39.34×2.62	1	
E14-12	160306030010	六角内梅花螺栓M6×12	BOLT M6×12	1	
E14-13	27942606BG01	水泵进水弯管	BEND PIPE	1	
E14-14	270116090000	弯管固定板	BOTTOM PLATE,BEND PIPE	2	
E14-15	160306030020	六角内梅花螺栓M6×16	BOLT M6×16	2	
E14-16	160306030070	六角内梅花螺栓M6×30	BOLT M6×30	5	
E14-17	270146060000	卡箍17	CLIP 17	4	
E14-18	150376060000	橡胶水管II	PIPE II	1	
E14-19	150366060000	橡胶水管 I	PIPE I	1	

E15 LUBRICATE SYSTEM (润滑系统分总成)

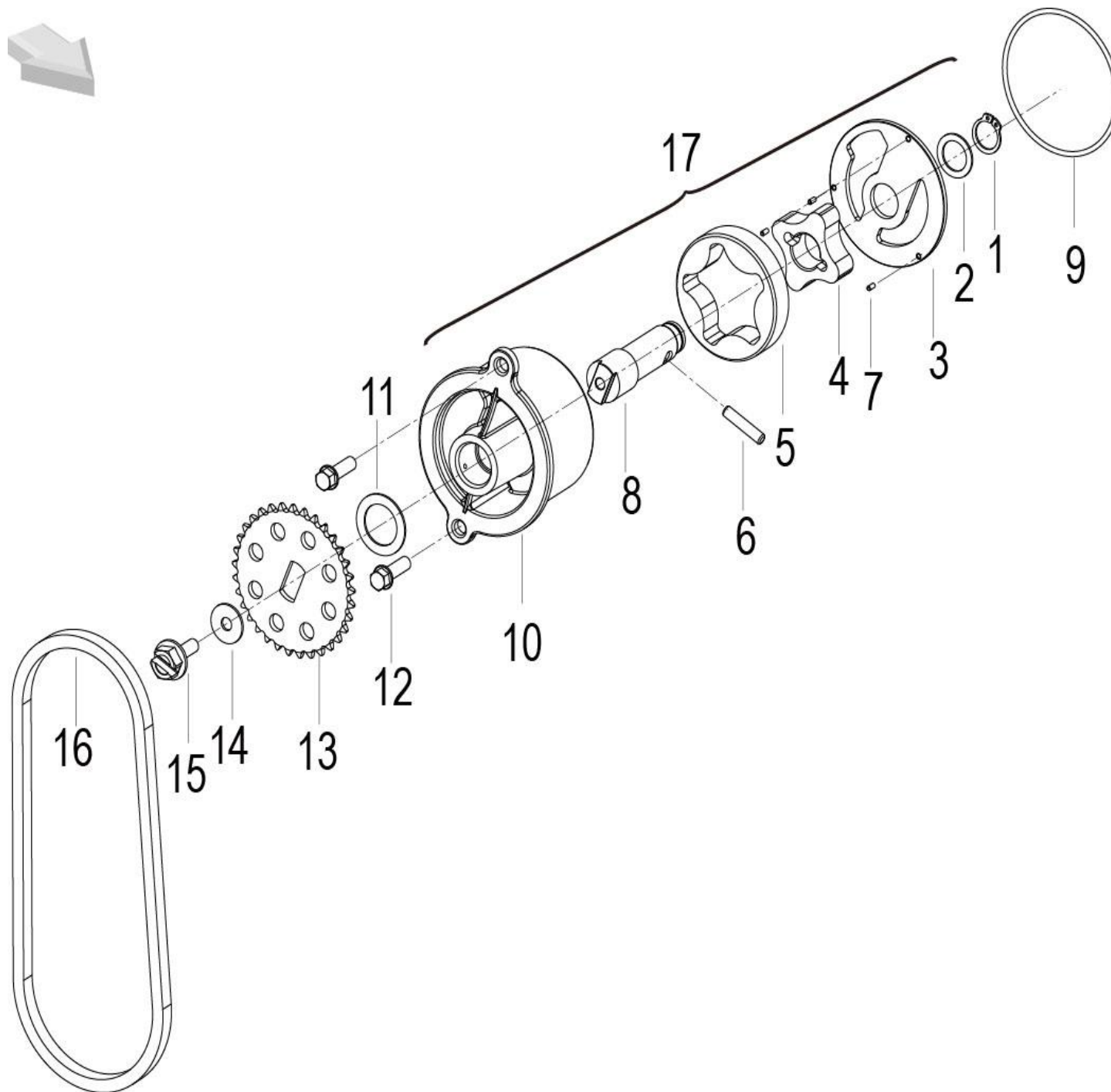

POSITION NO.	CODE	CN DESCRIPTION	EN DESCRIPTION	QTY / UNIT	REMARKS
E15-01	B080100014A1	轴用挡圈14	CIRCLIP 14	1	
E15-02	260066090000	垫片14×20×1	WASHER 14×20×1	1	
E15-03	260046060000	机油泵垫片	OIL PUMP GASKET	1	
E15-04	260026060000	机油泵内转子	OIL PUMP INNER ROTOR	1	
E15-05	260036060000	机油泵外转子	OIL PUMP OUTER ROTOR	1	
E15-06	260216090000	圆柱销Φ5×23.8	PIN Φ5×23.8	1	
E15-07	B091402005B4	圆柱销Φ2×5	PIN Φ2×5	3	
E15-08	260056060000	机油泵轴	OIL PUMP SHAFT	1	
E15-09	260136060000	O型圈 62.3×2.2	O RING 62.3×2.2	1	
E15-10	260016060000	机油泵体	OIL PUMP HOUSING	1	
E15-11	260076060000	垫片19×28×1	WASHER 19×28×1	1	
E15-12	270156030010	螺栓M6×20	BOLT M6×20	2	
E15-13	260066060010	机油泵从动链轮	OIL PUMP DIRVING GEAR	1	
E15-14	100115040000	垫片	WASHER	1	
E15-15	269206060000	机油泵螺栓	OIL PUMP BOLT	1	
E15-16	269056060000	机油泵链条	OIL PUMP DRIVE CHAIN	1	
E15-17	269016060000	机油泵组件	OIL PUMP ASSY	1	

E16 THROTTLE BODY ASSY (节流阀体分总成)

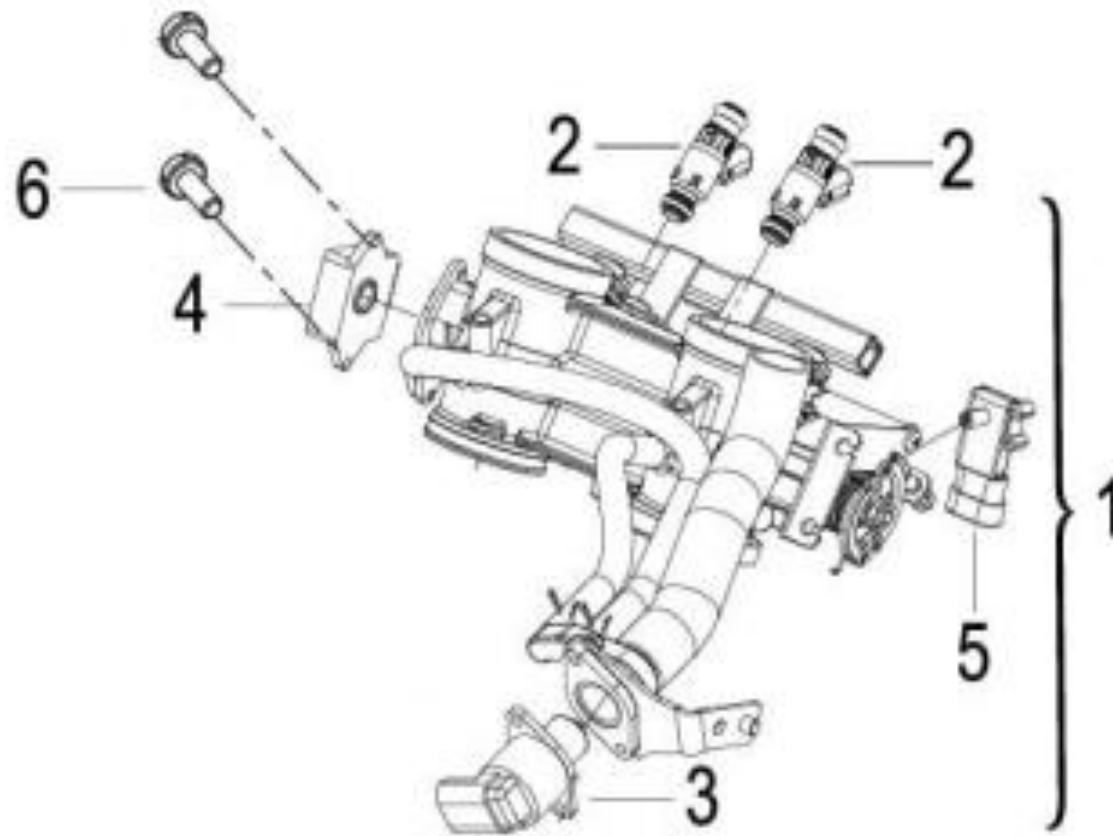

POSITION NO.	CODE	CN DESCRIPTION	EN DESCRIPTION	QTY / UNIT	REMARKS
E16-01	289006060020	节流阀体分总成	THROTTLE BODY ASSY	1	
E16-02	280446060020	喷油器	OIL INSUFFLATING IMPLEMENT	2	
E16-03	280476030000	步进电机	STEPPER MOTOR	1	
E16-04	280756030010	节气门位置传感器	THROTTLE LOCATION SENSOR	1	
E16-05	280106220000	进气压力传感器	INTAKE PRESSURE SENSOR	1	
E16-06	B1308040140H	螺钉M4×14	SCREW M4×14	2	